

Panasonic

Compact Fax
and Digital Answering System

Operating Instructions

Model No. **KX-FP145**

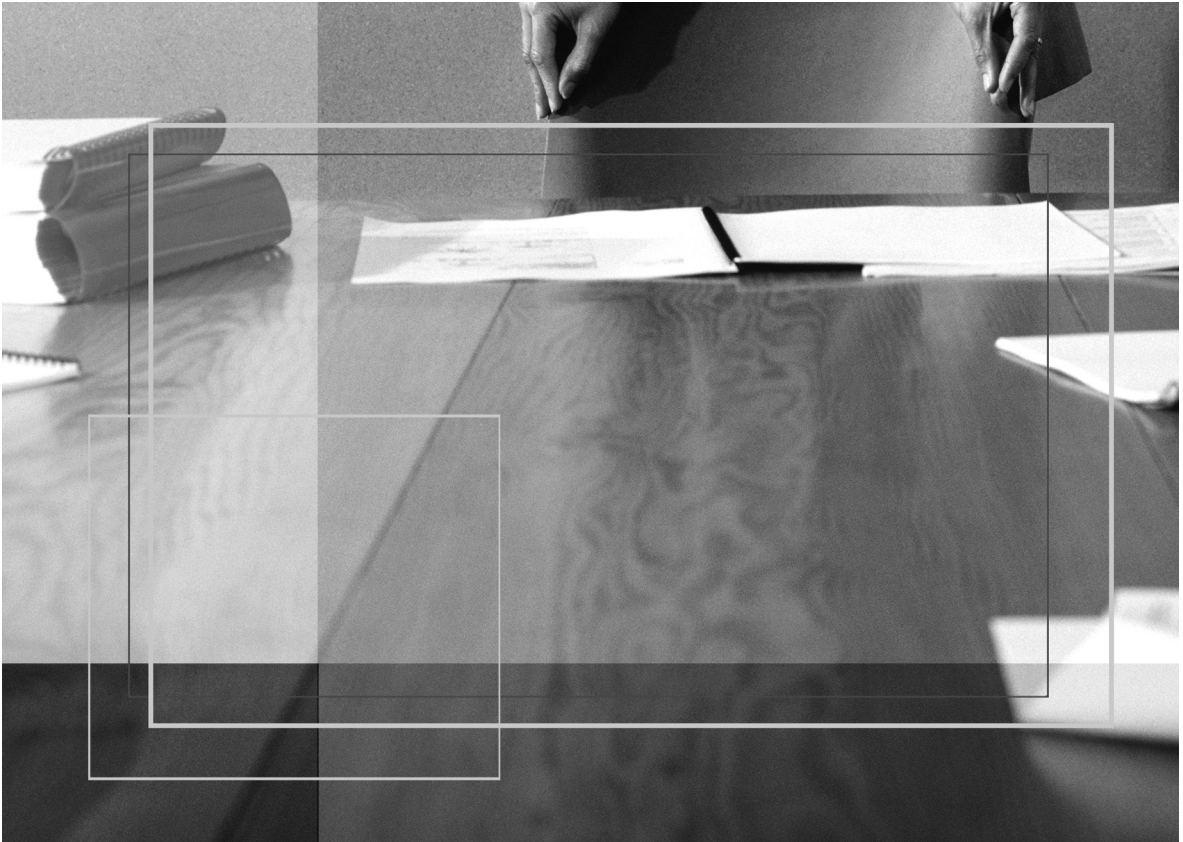

FOR FAX ADVANTAGE ASSISTANCE:

— PHONE CALL

1-800-HELP-FAX (1-800-435-7329)

— E-MAIL TO

consumer_fax@panasonic.com

for customers in the U.S.A. or Puerto Rico

— REFER TO

www.panasonic.com

for customers in the U.S.A. or Puerto Rico

Please read these Operating Instructions before using the unit and save for future reference.

This model is designed to be used only in the U.S.A.

How to use the operating instructions

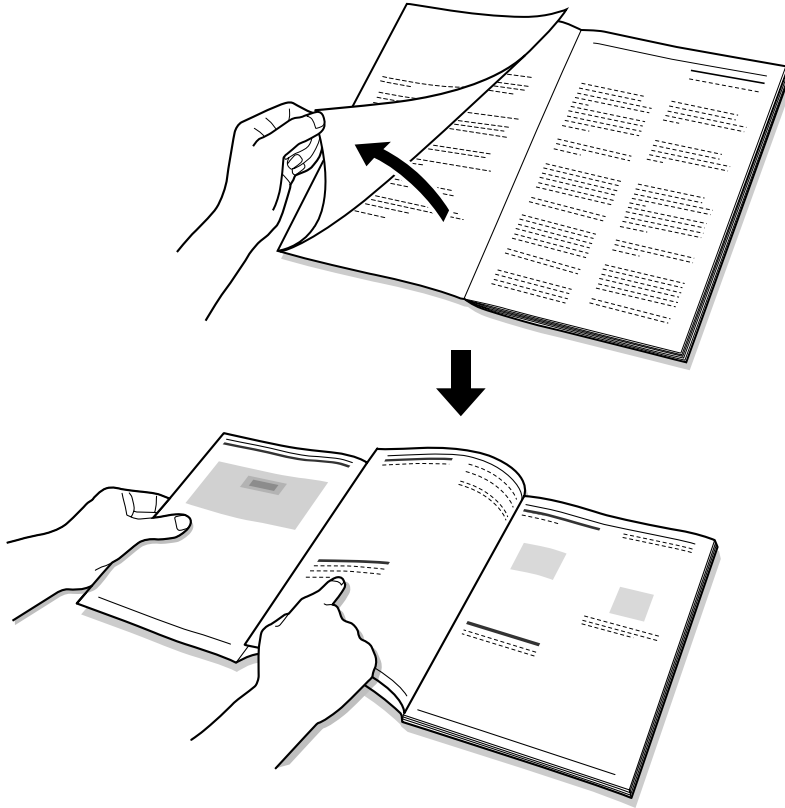

When following operating instructions, always keep the front cover page (next page) open so that you will find easy reference to the buttons.

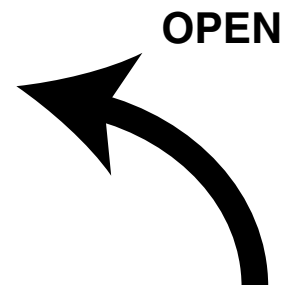

Location of Controls

Please keep this page open when following operating instructions.
For a description of each button, see page 9.

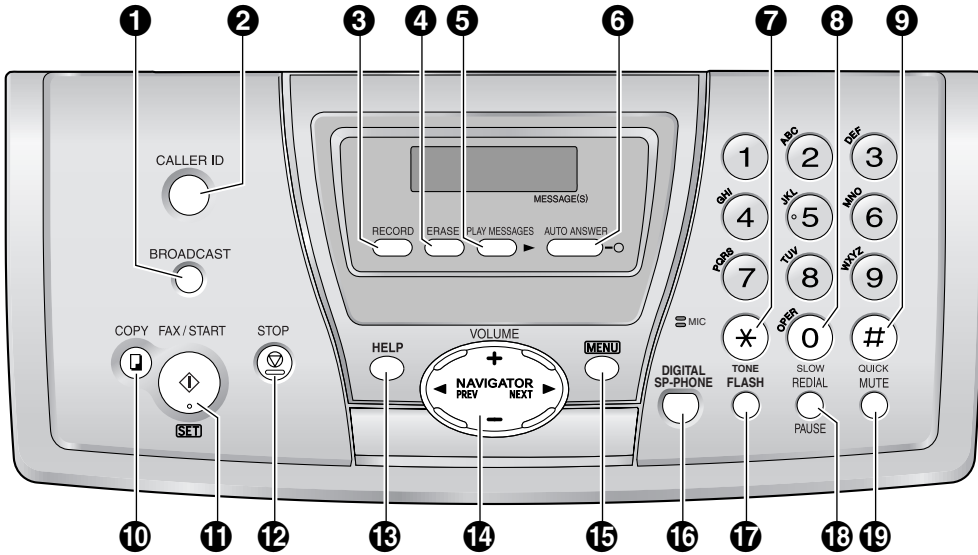

Keys (Listed in alphabetical order)

- | | | |
|---------------------|-----------------|-----------|
| AUTO ANSWER 6 | HELP 13 | REDIAL 18 |
| BROADCAST 1 | MENU 15 | SET 11 |
| CALLER ID 2 | MUTE 19 | SLOW 8 |
| COPY 10 | NAVIGATOR 14 | START 11 |
| DIGITAL SP-PHONE 16 | PAUSE 18 | STOP 12 |
| ERASE 4 | PLAY MESSAGES 5 | TONE 7 |
| FAX/START 11 | QUICK 9 | VOLUME 14 |
| FLASH 17 | RECORD 3 | |

Important safety instructions

When using this unit, basic safety precautions should always be followed to reduce the risk of fire, electric shock, or personal injury.

1. Read and understand all instructions.
2. Follow all warnings and instructions marked on this unit.
3. Unplug this unit from power outlets before cleaning. Do not use liquid or aerosol cleaners. Use a damp cloth for cleaning.
4. Do not use this unit near water, for example near a bathtub, wash bowl, kitchen sink, etc.
5. Place the unit securely on a stable surface. Serious damage and/or injury may result if the unit falls.
6. Do not cover slots and openings on the unit. They are provided for ventilation and protection against overheating. Never place the unit near radiators, or in a place where proper ventilation is not provided.
7. Use only the power source marked on the unit. If you are not sure of the type of power supplied to your home, consult your dealer or local power company.
8. For safety purposes this unit is equipped with a grounded plug. If you do not have this type of outlet, please have one installed. Do not defeat this safety feature by tampering with the plug.
9. Do not place objects on the power cord. Install the unit where no one can step or trip on the cord.
10. Do not overload power outlets and extension cords. This can result in the risk of fire or electric shock.
11. Never push any objects through slots in this unit. This may result in the risk of fire or electric shock. Never spill any liquid on the unit.
12. To reduce the risk of electric shock, do not disassemble this unit. Take the unit to an authorized service center when service is required. Opening or removing covers may expose you to dangerous voltage or other risks. Incorrect reassembly can cause electric shock when the unit is subsequently used.
13. Unplug this unit from power outlets and refer servicing to an authorized service center when the following conditions occur:
 - A. When the power cord is damaged or frayed.
 - B. If liquid has been spilled into the unit.
 - C. If the unit has been exposed to rain or water.
 - D. If the unit does not work normally by following the operating instructions. Adjust only controls covered by the operating instructions. Improper adjustment may require extensive work by an authorized service center.
 - E. If the unit has been dropped or physically damaged.
 - F. If the unit exhibits a distinct change in performance.
14. During thunderstorms, avoid using telephones except cordless types. There may be a remote risk of an electric shock from lightning.
15. Do not use this unit to report a gas leak, when in the vicinity of the leak.

SAVE THESE INSTRUCTIONS

CAUTION:

Installation

- Never install telephone wiring during a lightning storm.
- Never install telephone jacks in wet locations unless the jack is specifically designed for wet locations.
- Never touch uninsulated telephone wires or terminals unless the telephone line has been disconnected at the network interface.
- Use caution when installing or modifying telephone lines.
- Do not touch the plug with wet hands.

WARNING:

- To prevent the risk of fire or electrical shock, do not expose this product to rain or any type of moisture.

For best performance

- Keep the unit away from electrical noise generating devices, such as fluorescent lamps and motors.
- The unit should be kept free from dust, high temperature and vibration.
- The unit should not be exposed to direct sunlight.
- Do not place heavy objects on top of this unit.
- Wipe the outer surface of the unit with a soft cloth. Do not use benzine, thinner, or any abrasive powder.
- Do not use this unit near liquid—for example, near a bathtub, washbowl, sink, etc. Damp basements should also be avoided. The unit should be kept away from heat sources such as heaters, kitchen stoves, etc. It also should not be placed in rooms where the temperature is less than 5°C (41°F) or greater than 35°C (95°F).
- Store unused paper in the original packaging, in a cool and dry place. Not doing so may affect print quality.

1. Introduction and Installation

Accessories	
1.1 Included accessories	7
1.2 Accessory information	8
Finding the Controls	
1.3 Overview	8
1.4 Description of buttons.....	9
Installation	
1.5 Ink film	10
1.6 Handset cord	12
1.7 Paper tray	12
1.8 Recording paper.....	12

2. Preparation

Connections and Setup	
2.1 Connections	14
2.2 Selecting the way to use your fax machine	15
2.3 Case 1: TAM/FAX (Telephone Answering Machine/Fax)	16
2.4 Case 2: Distinctive Ring (1 phone line with 2 or more phone numbers)	17
2.5 Case 3: TEL ONLY	18
2.6 Case 4: FAX ONLY	19
Help Button	
2.7 Help function	20
Volume	
2.8 Adjusting volume	20
Initial Programming	
2.9 Date and time	21
2.10 Your logo.....	22
2.11 Your fax number	23

3. Telephone

Automatic Dialing	
3.1 Storing names and telephone numbers into the navigator directory	25
3.2 Making a phone call using the navigator directory.....	26
Recording	
3.3 Recording a telephone conversation	26
Caller ID	
3.4 Caller ID service	27
3.5 Viewing and calling back using caller information.....	27
3.6 Storing caller information into the navigator directory.....	29

4. Fax

Sending Faxes	
4.1 Sending a fax manually	30
4.2 Documents you can send.....	31
4.3 Sending a fax using the navigator directory	32
4.4 Broadcast transmission	32
Receiving Faxes	
4.5 Receiving a fax manually – [AUTO ANSWER] OFF	34
4.6 Receiving a fax automatically – [AUTO ANSWER] ON	35
4.7 Junk fax prohibitor (preventing fax reception from undesired callers)	36

5. Distinctive Ring

Distinctive Ring	
5.1 Distinctive Ring service from your phone company	38
5.2 Using two or more phone numbers on a single telephone line.....	38
5.3 Using three or more phone numbers on a single telephone line.....	38
5.4 Programming the ring pattern assigned for fax.....	39

6. Copy

Copying	
6.1 Making a copy	40

7. Answering Machine

Greeting	
7.1 Recording your greeting message....	42
Memo Message	
7.2 Leaving a message for others or yourself	42
Incoming Messages	
7.3 Listening to recorded messages	43
Remote Operation	
7.4 Operating from a remote location....	44
Voice Mailbox	
7.5 Allowing callers to leave private messages	46
7.6 Recording your mailbox greeting messages	46
7.7 Listening to recorded mailbox messages	47
7.8 Listening to recorded mailbox messages from a remote location	48
Option	
7.9 Transferring recorded messages to another telephone	48

8. Programmable Features

Features

8.1	Programming	50
8.2	Basic features.....	51
8.3	Advanced features.....	52
8.4	Direct commands for programming features.....	55

9. Help

Error Messages

9.1	Error messages – Reports	58
9.2	Error messages – Display	58

Frequently Asked Questions

9.3	When a function does not work, check here	60
-----	--	----

Jams

9.4	Recording paper jams	63
9.5	Document jams – sending.....	66

Cleaning

9.6	Recording paper feeder cleaning	66
9.7	Document feeder/scanner glass cleaning	67
9.8	Thermal head cleaning.....	68

10. Caller IQ Feature

Caller IQ Feature

10.1	openLCR service for the Caller IQ feature	70
10.2	To turn the Caller IQ ON / OFF.....	70
10.3	Updating the rate table (downloading the rate table)	70
10.4	Downloading information	71
10.5	Viewing information	71
10.6	Printing information	71

11. General Information

Printed Reports

11.1	Reference lists and reports	72
------	-----------------------------------	----

Specifications

11.2	Technical data about this product.....	73
------	--	----

FCC and Other Information

11.3	FCC and Other Information	75
------	---------------------------------	----

Limited Warranty

11.4	Limited Warranty	77
------	------------------------	----

Customer Services

11.5	Customer Services directory	79
------	-----------------------------------	----

12. Index

12.1	Index.....	80
------	------------	----

1.1 Included accessories

No.	Item	Part number ^{*1}	Quantity	Specifications
①	Power cord	PFJA1030Z	1	-----
②	Telephone line cord	PQJA10075Z	1	-----
③	Handset	PFJXH0430Z	1	-----
④	Handset cord	PFJA04C001Z	1	-----
⑤	Paper tray	PFKS1104Z1	1	-----
⑥	Starter ink film (10 meters long)	-----	1	prints about 30 letter-sized pages. ^{*2}
⑦	Operating instructions	PFQX2006Z	1	-----
⑧	Quick installation guide	PFQW2146Z	1	-----

*1 Part numbers are subject to change without notice.

*2 For replacement film, see page 8.

Note:

- If any items are missing or damaged, check with the place of purchase.
- Save the original carton and packing materials for future shipping and transportation of the unit.

①

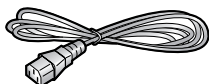

②



③

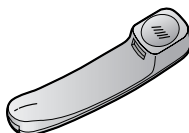

④

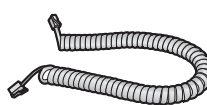

⑤

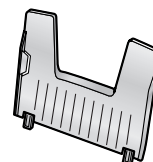

⑥

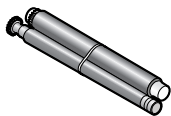

⑦



⑧

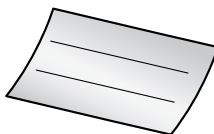

1.2 Accessory information

The included film roll is 10 meters (32¹/₂') long and prints about 30 letter-sized pages.

Accessories for this unit can be ordered online or by fax.

- **Replacement film*1 (KX-FA92):** 35 m (114') × 2 rolls (Each roll will print about 113 letter-sized pages.)

*1 To ensure the unit operates properly, we recommend the use of a Panasonic replacement film. **The ink film is not reusable. Do not rewind and use the ink film again.**

To place an order online (for customers in the U.S.A. ONLY)

Visit our web site:

<http://www.panasonic.com/store>

- **For questions regarding online orders:**

E-mail: specialty@panasonic.com

Telephone: 1-866-888-2929

To place an order by fax

Fax: 1-800-237-9080

Include:

- your name, shipping address and telephone number
- credit card type, number, expiration date and your signature
- part number and quantity

1.3 Overview

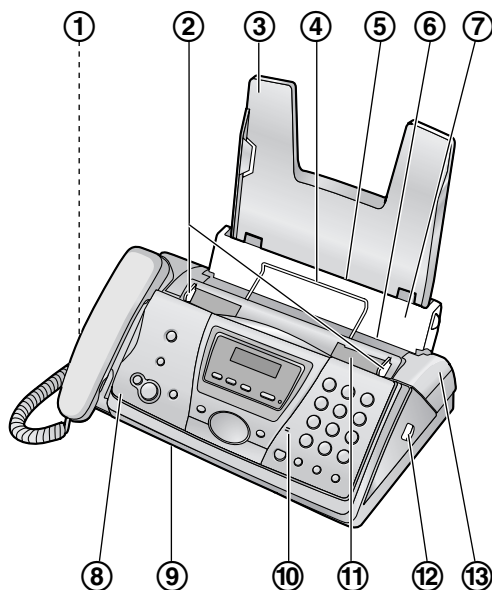

- ① **Speaker**
- ② **Document guides**
- ③ **Paper tray**
- ④ **Recording paper support**
- ⑤ **Recording paper entrance**
- ⑥ **Recording paper exit**
- ⑦ **Tension plate**
- ⑧ **Front cover**
- ⑨ **Document exit**
- ⑩ **Microphone**
- ⑪ **Document entrance**
- ⑫ **Green button (Back cover release button)**
- ⑬ **Back cover**

Note:

- Remove all the blue shipping tapes before installation.

1.4 Description of buttons

- Keep the front cover page open for button locations.
- 1 [BROADCAST]**
 - To transmit a document to multiple parties (page 33).
- 2 [CALLER ID]**
 - To use Caller ID features (page 27, 29).
- 3 [RECORD]**
 - To record messages (page 42).
- 4 [ERASE]**
 - To erase messages (page 42, 43).
- 5 [PLAY MESSAGES]**
 - To play messages (page 43).
- 6 [AUTO ANSWER]**
 - To turn ON/OFF the AUTO ANSWER setting (page 34, 35).
- 7 [TONE]**
 - To change from pulse to tone temporarily during dialing when your line has rotary pulse services.
- 8 [SLOW]**
 - To slow down message playback (page 43).
- 9 [QUICK]**
 - To speed up message playback (page 43).
- 10 [COPY]**
 - To initiate copying (page 40).
- 11 [FAX/START][SET]**
 - To initiate fax transmission or reception.
 - To store a setting during programming.
- 12 [STOP]**
 - To stop an operation or programming.
- 13 [HELP]**
 - To print a quick reference (page 20).
- 14 [NAVIGATOR][VOLUME]**
 - To adjust volume (page 20).
 - To search for a stored item (page 26, 32).
 - To select features or feature settings during programming (page 50).
 - To navigate to the next operation.
- 15 [MENU]**
 - To initiate or exit programming.
- 16 [DIGITAL SP-PHONE]**
 - For speakerphone operation (page 26).
- 17 [FLASH]**
 - To access special telephone services or for transferring extension calls.

- 18 [REDIAL][PAUSE]**
 - To redial the last number dialed.
 - To insert a pause during dialing.
- 19 [MUTE]**
 - To mute your voice to the other party during a conversation. Press this button again to resume the conversation.

1.5 Ink film

1.5.1 Installing the ink film

- 1 Open the front cover by pulling up the center part.

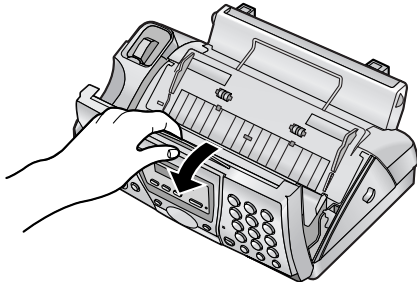

- 2 Release the back cover by pushing the green button (1).

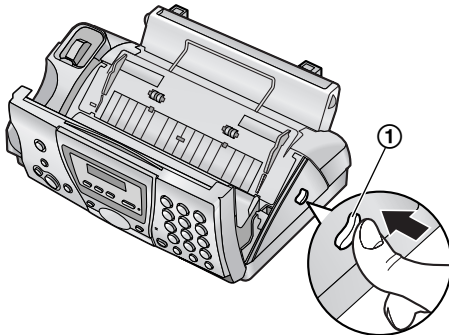

- 3 Open the back cover.

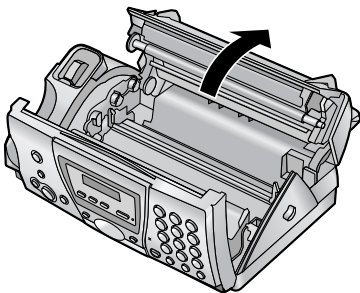

- 4 Insert the front ink film roll by inserting its blue gear (1) into the left slot of the unit (2). Insert the rear ink film roll (3).

- The ink film is safe to touch, and will not rub off on your hands like carbon paper.

- Make sure the blue gear (1) and white gear (4) are installed as shown.

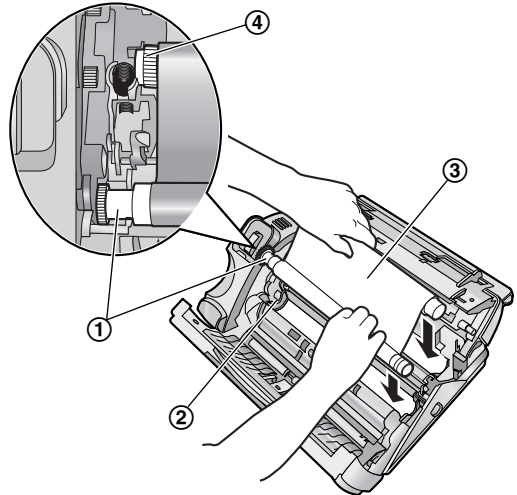

- 5 Turn the blue gear (1) in the direction of the arrow until the ink film is tight (2).

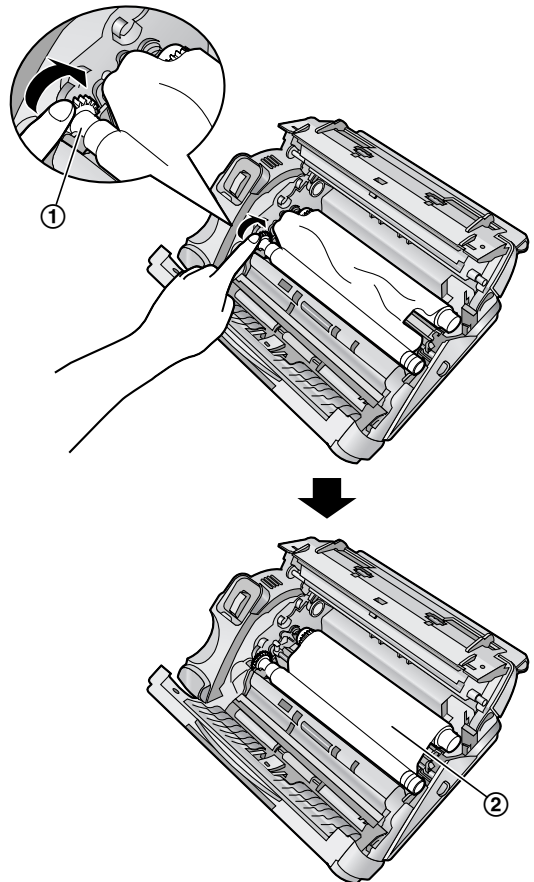

- Make sure that the ink film is wrapped around the blue core (③) at least once.

Correct

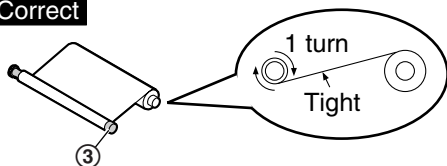

Incorrect

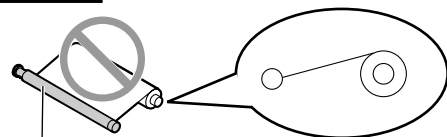

The ink film is not wrapped around the blue core.

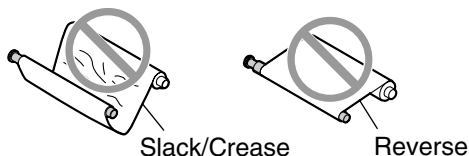

- 6 Close the back cover securely by pushing down on the notched area at both ends (①).

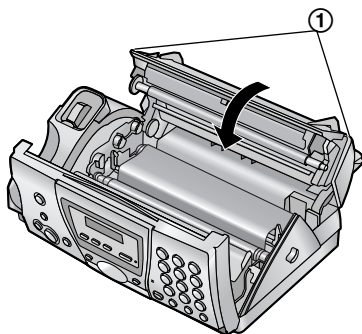

- 7 Close the front cover securely.

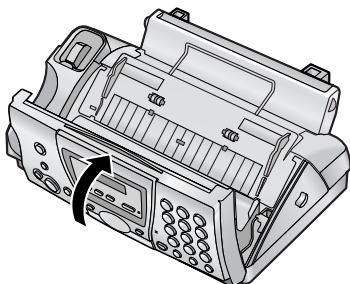

1.5.2 Replacing the ink film

The included film roll is a starter ink film. To ensure that the unit operates properly, we recommend the use of Panasonic replacement film. See page 8 for accessory information.

- We cannot be responsible for any damage to the unit or degradation of print quality which may occur from the use of non-Panasonic replacement film.

Important:

- Remove the recording paper and the paper tray beforehand, or the paper may misfeed or jam.

- 1 Open the covers (see steps 1 to 3 on page 10).
- 2 Remove the used core (①) and used ink film (②).

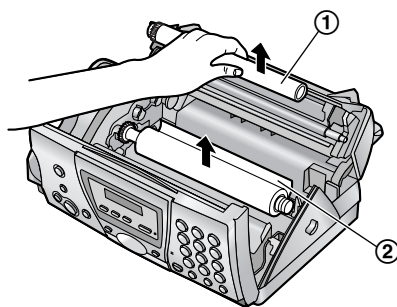

- 3 Remove the stoppers (①) and tags (②) from the new ink film (③).

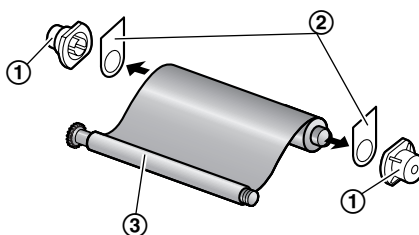

- 4 Insert the ink film and close the covers (see steps 4 to 7 on page 10).
- 5 Install the paper tray (page 12), then insert the recording paper (page 12).

1.6 Handset cord

Connect the handset cord (①).

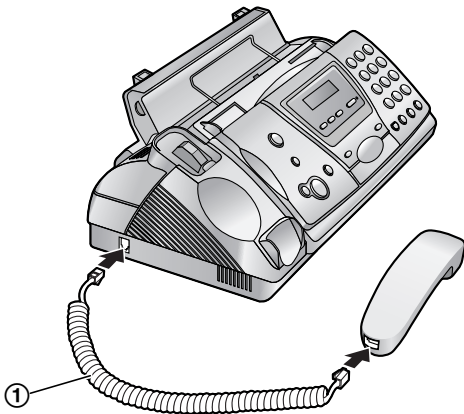

1.7 Paper tray

Insert the tabs (①) on the paper tray (②) into the slots on the back of the unit (③).

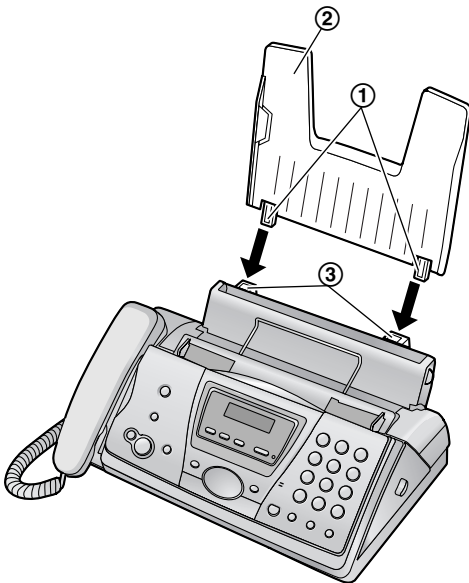

1.8 Recording paper

The unit can hold:

- Up to 30 sheets of 60 g/m² to 80 g/m² (16 lb. to 21 lb.) paper.
- Up to 20 sheets of 90 g/m² (24 lb.) paper.

Please read the note on page 74 for important information on recording paper.

For superior results, we recommend Hammermill® Jet Print paper.

1 Pull the tension plate forward (①).



2 Fan the paper to prevent paper jams.

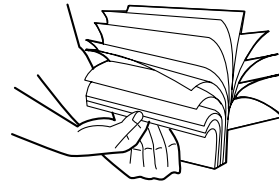

3 Insert the paper, print-side down (①).
• The paper should not be over the tab (②).

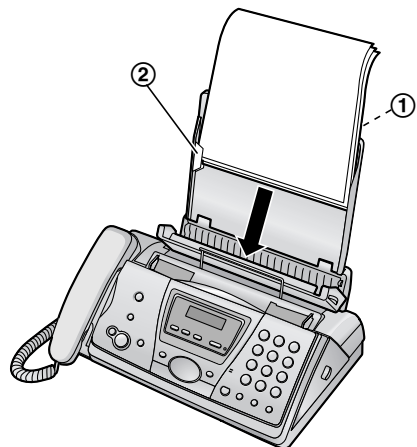

- 4** Push the tension plate back (①).

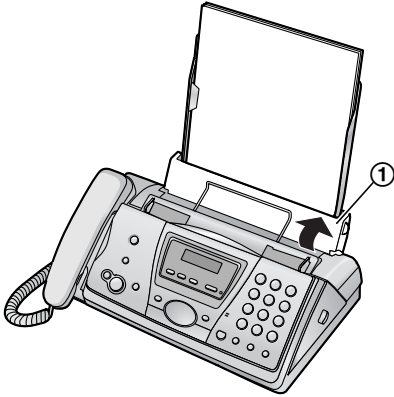

- If the paper is not inserted correctly, readjust the paper, or the paper may jam.

Correct

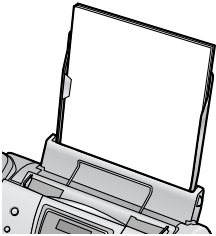

Incorrect

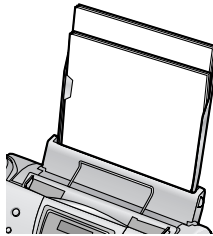

2.1 Connections

Caution:

- When you operate this product, the power outlet should be near the product and easily accessible.

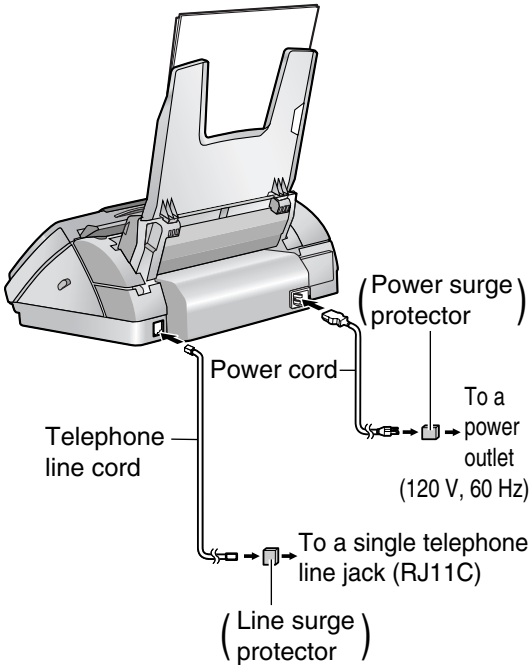

Note:

- If any other device is connected on the same line, this unit may disturb the network condition of the device.

Using surge protectors

- The warranty does not cover damage due to power line surges or lightning. For additional protection, we recommend the use of a surge protector.

If you use this unit with a computer or subscribe to an xDSL service

Fax transmission/reception may be disturbed, or you may hear interference noise during telephone conversation. A filter to prevent this is provided from your service company. Please

attach the filter to the telephone line cord of the fax machine.

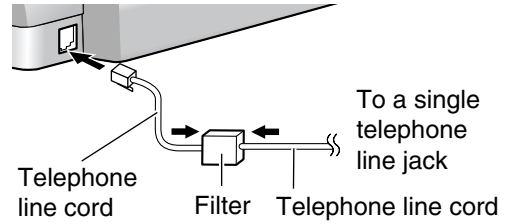

2.2 Selecting the way to use your fax machine

Depending on your situation, you can select the way you prefer to use your fax machine in Quick Setup feature #00.

You can print out the Quick Setup Guide as a reference.

- **Case 1:** TAM/FAX (Telephone Answering Machine/Fax) (page 16)
- **Case 2:** Distinctive Ring (1 phone line with 2 or more phone numbers) (page 17)
- **Case 3:** TEL ONLY (page 18)
- **Case 4:** FAX ONLY (page 19)

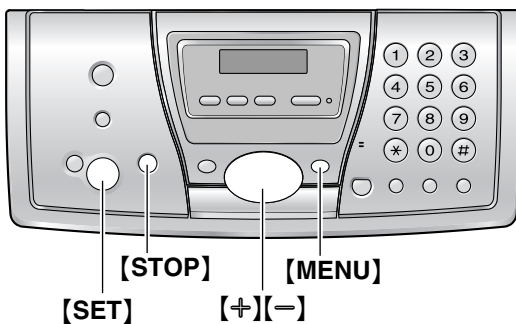

- 1 Press **[MENU]**.
- 2 Press **[#]** then **[0][0]**.

```
QUICK SETUP
PRESS SET
```

- 3 Press **[SET]**.

```
PRINT SETUP?
YES:SET/NO:STOP
```

- 4 Press **[SET]** again to print the Quick Setup Guide.
 - If you do not wish to print it, press **[STOP]**.
- 5 Press **[+]** or **[-]** repeatedly to display the desired setting.
- 6 Press **[SET]**.
- 7 Press **[MENU]**.

2.3 Case 1: TAM/FAX (Telephone Answering Machine/Fax)

2.3.1 Your situation

You wish to use this unit as a telephone answering machine and fax.

2.3.2 How to setup

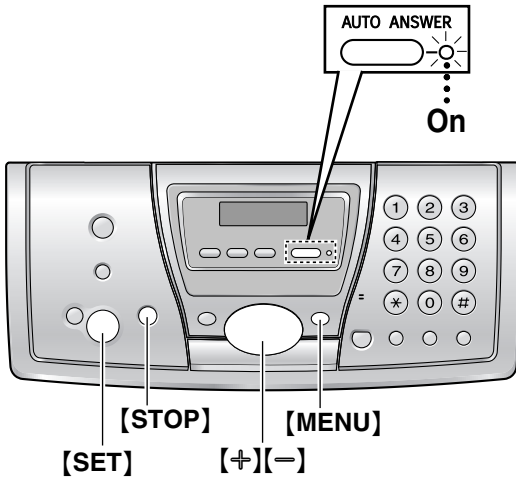

- 1 Press **[MENU]**.
- 2 Press **[*]** then **[0][0]**.

```
QUICK SETUP
PRESS SET
```

- 3 Press **[SET]**.

```
PRINT SETUP?
YES:SET/NO:STOP
```

- 4 Press **[SET]** again to print the Quick Setup Guide.
 - If you do not wish to print it, press **[STOP]**.

- 5 Press **[+]** or **[-]** repeatedly to display the following.

```
SELECT A SETUP
=TAM/FAX    [+]
```

- 6 Press **[SET]**.
 - The **[AUTO ANSWER]** indicator turns ON.
- 7 Press **[MENU]**.

Note:

- You can change the ring setting in TAM/FAX mode (feature #06 on page 51).

2.3.3 How to receive calls

When receiving calls, the unit works as a telephone answering machine and fax.

- If the call is a phone call, the unit will record a voice message automatically.
- If a fax calling tone is detected, the unit will receive the fax automatically.

Note:

- Do not connect an answering machine to the same telephone line. If one is connected, set the automatic answer feature to OFF by pressing **[AUTO ANSWER]** repeatedly.
- Do not subscribe to voice mail service as it may disturb fax reception. If you do subscribe to a voice mail service, call Panasonic Fax Advantage assistance at 1-800-435-7329 for more information.

2.4 Case 2: Distinctive Ring (1 phone line with 2 or more phone numbers)

2.4.1 Your situation

You wish to use this unit to receive faxes using one phone number and to handle phone calls using another phone number. You must get an additional phone number by subscribing to your telephone company's Distinctive Ring service.

- Distinctive Ring service may be called Identia Ring service. The name of the service depends on the telephone company.

2.4.2 How to setup

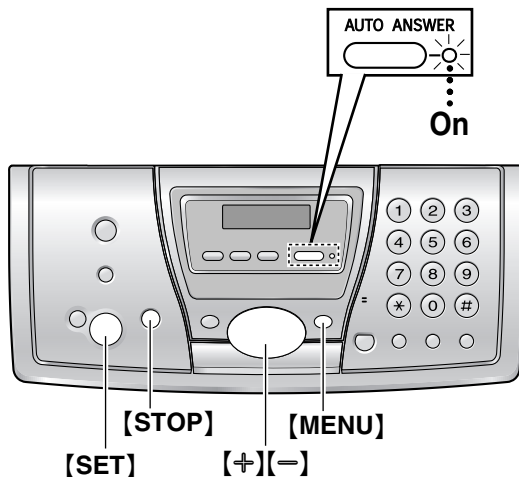

- 1 Subscribe to Distinctive Ring service with your local telephone company to get a new phone number.
- 2 Press [MENU].
- 3 Press [Ⓜ] then [0][0].

```
QUICK SETUP
PRESS SET
```

- 4 Press [SET].

```
PRINT SETUP?
YES:SET/NO:STOP
```

- 5 Press [SET] again to print the Quick Setup Guide.
 - If you do not wish to print it, press [STOP].

- 6 Press [+] or [-] repeatedly to display the following.

```
SELECT A SETUP
=DIST. RING [±]
```

- 7 Press [SET].
 - The [AUTO ANSWER] indicator turns ON.

- 8 Press [MENU].

Note:

- You can change the ring setting in TAM/FAX mode (feature #06 on page 51).

2.4.3 How to receive calls

If the number assigned for phone calls is called, the fax machine will ring and record a voice message automatically.

If the number assigned for fax is called, the fax machine will ring and start fax reception automatically.

If you subscribe to three or more phone numbers on a single telephone line

Each phone number will be assigned a different ring pattern by the phone company.

To use one number for fax, program the ring pattern assigned for fax (feature #32 on page 39) by referring to the ring pattern table (page 38).

2.5 Case 3: TEL ONLY

2.5.1 Your situation

You wish to use the fax machine and an extension telephone in a different room. Most incoming calls are phone calls and the fax machine is seldom used for fax reception.

2.5.2 How to setup

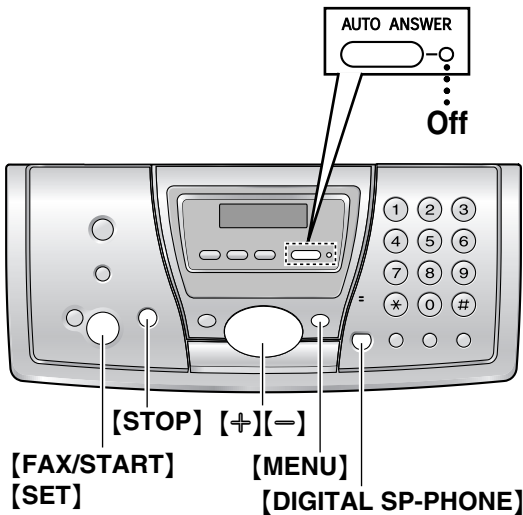

- 1 Press **[MENU]**.
- 2 Press **[*][0][0]**.

```
QUICK SETUP
PRESS SET
```

- 3 Press **[SET]**.

```
PRINT SETUP?
YES:SET/NO:STOP
```

- 4 Press **[SET]** again to print the Quick Setup Guide.
 - If you do not wish to print it, press **[STOP]**.

- 5 Press **[+]** or **[-]** repeatedly to display the following.

```
SELECT A SETUP
=TEL ONLY    [±]
```

- 6 Press **[SET]**.
 - The **[AUTO ANSWER]** indicator turns OFF.

- 7 Press **[MENU]**.

2.5.3 How to receive calls

You can receive a fax with the fax machine or an extension telephone.

With the fax machine

1. Press **[DIGITAL SP-PHONE]** or lift the handset to answer the call.
2. When:
 - document reception is required,
 - a fax calling tone (slow beep) is heard, or
 - no sound is heard,press **[FAX/START]**.
3. Replace the handset if using it.
 - The fax machine will start fax reception.

With an extension telephone

1. When the extension telephone rings, lift the handset of the extension telephone.
2. When:
 - document reception is required,
 - a fax calling tone (slow beep) is heard, or
 - no sound is heard,press **[*][#][9]** (default fax activation code) **firmly**.
3. Replace the handset.
 - The fax machine will start fax reception.

Note:

- To receive fax documents using the extension telephone, you must set the remote fax activation to ON (feature #41 on page 53) beforehand. The default setting is "ON".

2.6 Case 4: FAX ONLY

2.6.1 Your situation

You wish to use the fax machine only for fax reception/transmission.

2.6.2 How to setup

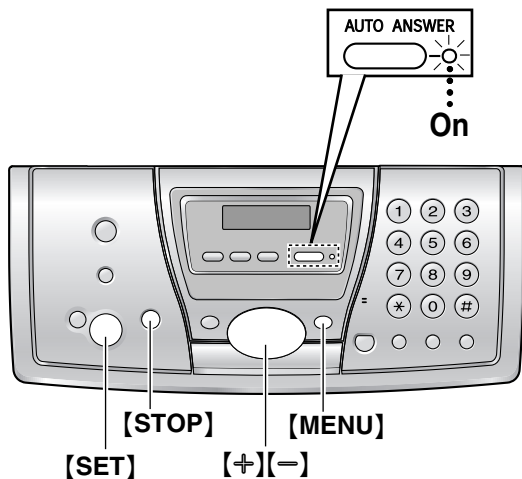

2.6.3 How to receive faxes

Leave AUTO ANSWER ON. When the other party sends a fax, the fax machine will receive it automatically.

- 1 Press **[MENU]**.
- 2 Press **[#]** then **[0][0]**.

```
QUICK SETUP
PRESS SET
```

- 3 Press **[SET]**.

```
PRINT SETUP?
YES:SET/NO:STOP
```

- 4 Press **[SET]** again to print the Quick Setup Guide.
 - If you do not wish to print it, press **[STOP]**.

- 5 Press **[+]** or **[-]** repeatedly to display the following.

```
SELECT A SETUP
=FAX ONLY [±]
```

- 6 Press **[SET]**.
 - The **[AUTO ANSWER]** indicator turns ON.
- 7 Press **[MENU]**.

Note:

- You can change the ring setting in FAX ONLY mode (feature #06 on page 51).

2.7 Help function

The unit contains helpful information which can be printed for quick reference.

Send guide:

How to send faxes. (The information is announced by a voice guide and is not printed out.)

Basic settings:

How to set the date, time, your logo and fax number.

Feature list:

How to program the features.

Directory:

How to store names and numbers in the navigator directory and how to dial them.

TAM operation:

How to use the Telephone Answering Machine.

Fax sending/receiving:

Help with problems sending/receiving faxes.

Copier:

How to use the copier function.

Q and A:

Frequently asked questions and answers.

Errors:

Explanation of error messages shown on the display.

Reports:

List of available reports.

Caller ID:

How to use the Caller ID features.

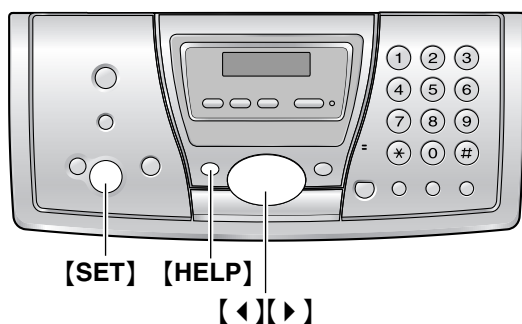

- 1 Press [HELP].
- 2 Press [◀] or [▶] repeatedly to display the desired item.
- 3 Press [SET].
 - The selected item will be printed.

2.8 Adjusting volume

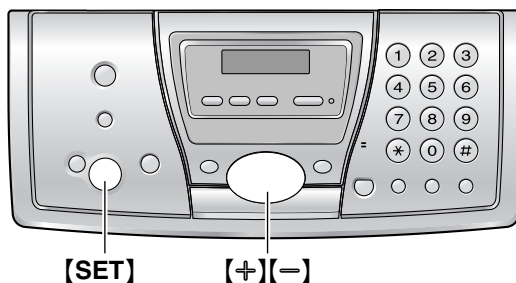

2.8.1 Ringer volume

4 levels (high/medium/low/off) are available.

While the unit is idle, press [+] or [-].

- If any documents are in the document entrance, you cannot adjust the volume. Confirm that there are no documents in the entrance.

To turn the ringer OFF

1. Press [-] repeatedly to display "RINGER OFF= OK?".
2. Press [SET].
 - When a call is received, the unit will not ring and will display "INCOMING CALL".
 - To turn the ringer back ON, press [+].

Ringer pattern

- You can select one of three ringer patterns (feature #17, page 51).

2.8.2 Handset receiver volume

5 levels (high to low) are available.

While using the handset, press [+] or [-].

2.8.3 Speaker volume

8 levels (high to low) are available.

While using the speakerphone, press [+] or [-].

2.8.4 Fax voice guidance volume

9 levels (high to off) are available.

While listening to fax voice guidance, press [+] or [-].

2.8.5 Answering machine volume

9 levels (high to off) are available.

While listening to recorded messages, press [+] or [-].

2.9 Date and time

You must set the date and time.

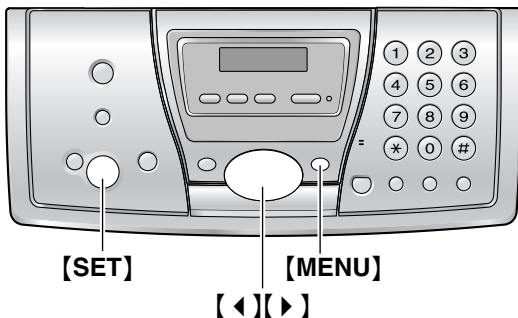

- 1 Press [MENU].

```
SYSTEM SETUP
PRESS NAVI. [◀ ▶]
```

- 2 Press [◀] or [▶] repeatedly to display the following.

```
SET DATE & TIME
PRESS SET
```

- 3 Press [SET].
 - Cursor (■) will appear on the display.

```
M:01/D:01/Y:04
TIME: 12:00AM
```

- 4 Enter the current month/day/year by selecting 2 digits for each.

Example: August 10, 2004

Press [0][8] [1][0] [0][4].

```
M:08/D:10/Y:04
TIME: 12:00AM
```

- 5 Enter the current hour/minute by selecting 2 digits for each. Press [✱] to select "AM" or "PM".

Example: 10:15 PM (12 hour clock entry)

1. Press [1][0] [1][5].

```
M:08/D:10/Y:04
TIME: 10:15AM
```

2. Press [✱] repeatedly to display "PM".

```
M:08/D:10/Y:04
TIME: 10:15PM
```

- 6 Press [SET].
 - The next feature will be displayed.

- 7 Press [MENU] to exit the program.

Note:

- The date and time will be printed on each page transmitted from your unit.

- The accuracy of the clock is approximately ± 60 seconds a month.

To correct a mistake

Press [◀] or [▶] to move the cursor to the incorrect number, and make the correction.

If you have subscribed to a Caller ID service

The date and time will be automatically set according to the received caller information.

If you have registered with openLCR service

The date and time will be automatically set.

2. Preparation

2.10 Your logo

The logo can be your company, division or name.

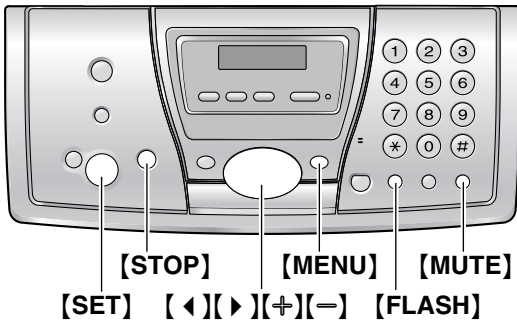

- 1 Press **[MENU]**.

```
SYSTEM SETUP
PRESS NAVI. [◀ ▶]
```

- 2 Press **[◀]** or **[▶]** repeatedly to display the following.

```
YOUR LOGO
PRESS SET
```

- 3 Press **[SET]**.
 - Cursor (█) will appear on the display.

```
LOGO=█
```

- 4 Enter your logo, up to 30 characters. See the character table on page 22 for details.

- 5 Press **[SET]**.
 - The next feature will be displayed.

- 6 Press **[MENU]** to exit the program.

Note:

- Your logo will be printed on each page transmitted from your unit.

To select characters with the dial keypad

Keys	Characters
[1]	1 [] { } + - / = , . _ ` : ; ?
[2]	A B C a b c 2
[3]	D E F d e f 3
[4]	G H I g h i 4
[5]	J K L j k l 5
[6]	M N O m n o 6

Keys	Characters
[7]	P Q R S p q r s 7
[8]	T U V t u v 8
[9]	W X Y Z w x y z 9
[0]	0 () < > ! " # \$ % & ¥ * @ ^ ' →
[#]	To change capital or lower-case letter.
[FLASH]	Hyphen button
[MUTE]	Insert button
[STOP]	Delete button

Note:

- To enter another character located on the same number key, press **[▶]** to move the cursor to the next space.

To enter your logo

Example: "BILL"

1. Press **[2]** 2 times.

```
LOGO=B█
```

2. Press **[4]** 3 times.

```
LOGO=BI█
```

3. Press **[5]** 3 times.

```
LOGO=BIIL█
```

4. Press **[▶]** to move the cursor to the next space and press **[5]** 3 times.

```
LOGO=BILIL█
```

To change capital or lower-case letters

Pressing the **[#]** key will change to capital or lower-case alternately.

1. Press **[2]** 2 times.

```
LOGO=B█
```

2. Press **[4]** 3 times.

```
LOGO=BI█
```

3. Press **[#]**.

```
LOGO=Bi█
```

4. Press [5] 3 times.

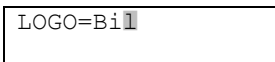

To correct a mistake

Press [◀] or [▶] to move the cursor to the incorrect character, and make the correction.

To delete a character

Press [◀] or [▶] to move the cursor to the character you want to delete and press [STOP].

- To erase all of the digits, press and hold [STOP].

To insert a character

1. Press [◀] or [▶] to move the cursor to the position to the right of where you want to insert the character.
2. Press [MUTE] to insert a space and enter the character.

To select characters using [+] or [-]

Instead of pressing the dial keys, you can select characters using [+] or [-].

1. Press [+] or [-] repeatedly to display the desired character.
2. Press [▶] to move the cursor to the next space.
 - The character displayed is inserted.
3. Return to step 1 to enter the next character.

Display order of characters

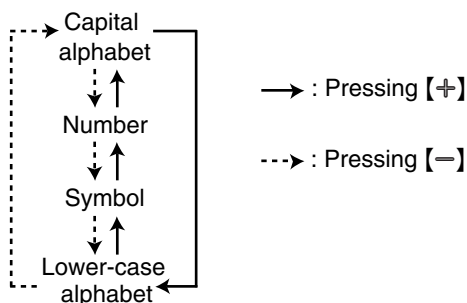

2.11 Your fax number

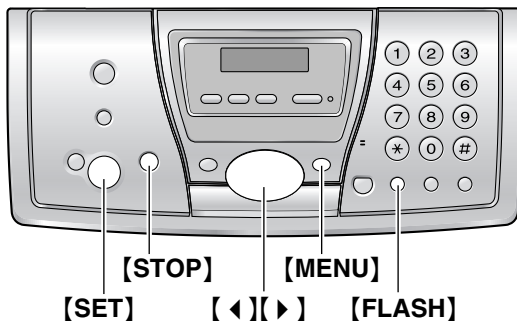

1 Press [MENU].



2 Press [◀] or [▶] repeatedly to display the following.



3 Press [SET].

- Cursor (■) will appear on the display.

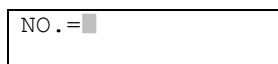

4 Enter your fax number, up to 20 digits.

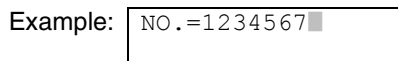

5 Press [SET].

- The next feature will be displayed.

6 Press [MENU] to exit the program.

Note:

- Your fax number will be printed on each page transmitted from your unit.
- The [*] button enters a “+” and the [#] button enters a space.
Example: +234 5678
 Press [*][2][3][4][#][5][6][7][8].
- To enter a hyphen in a telephone number, press [FLASH].

To correct a mistake

Press [◀] or [▶] to move the cursor to the incorrect number, and make the correction.

To delete a number

Press [◀] or [▶] to move the cursor to the number you want to delete and press [STOP].

2. Preparation

- To erase all of the digits, press and hold **[STOP]**.

3.1 Storing names and telephone numbers into the navigator directory

For rapid access to frequently dialed numbers, the unit provides the navigator directory (100 items).

- You can also send faxes using the navigator directory (page 32).

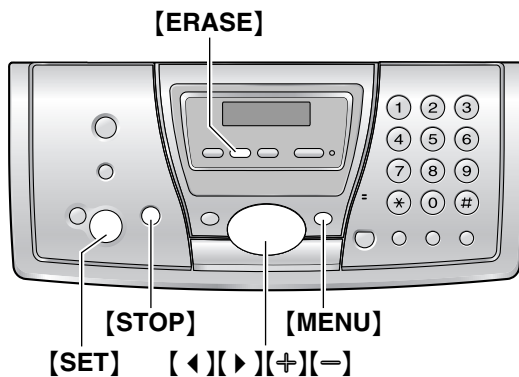

- Press **[MENU]** repeatedly to display "DIRECTORY SET".
- Press **[*]**.
Example:

DIRECTORY 1 ITEM

- Enter the name, up to 10 characters (see page 22 for instructions).
- Press **[SET]**.
- Enter the telephone number, up to 30 digits.
- Press **[SET]**.
 - To program other items, repeat steps 3 to 6.
- Press **[MENU]**.

Helpful hints:

- For your convenience, HELP-FAX (1-800-435-7329) has been stored in the directory. If you cannot solve a problem, call the number (page 26). If not needed, you can erase it (page 25).
- You can confirm the stored items in the telephone number list (page 72).

Note:

- If "SPACE= 5 DIRS." is displayed, you can store only 5 more items.
- A hyphen or a space entered in a telephone number counts as 2 digits.

To correct a mistake

Press **[◀]** or **[▶]** to move the cursor to the incorrect character/number, and then make the correction.

To delete a character/number

Press **[◀]** or **[▶]** to move the cursor to the character/number you want to delete, and press **[STOP]**.

- To erase all of the digits, press and hold **[STOP]**.

3.1.1 Editing a stored item

- Press **[▶]**.
- Press **[+]** or **[-]** repeatedly to display the desired item.
- Press **[MENU]**.
- Press **[*]**.
 - If you do not need to edit the name, skip to step 6.
- Edit the name (see the storing procedure on page 25 for instructions).
- Press **[SET]**.
 - If you do not need to edit the telephone number, skip to step 8.
- Edit the telephone number. For further details, see the storing procedure on page 25.
- Press **[SET]**.

3.1.2 Erasing a stored item

- Press **[▶]**.
- Press **[+]** or **[-]** repeatedly to display the desired item.
- Press **[MENU]**.
- Press **[#]**.
 - To cancel erasing, press **[STOP]**.
- Press **[SET]**.

Another method to erase a stored item

- Press **[▶]**.
- Press **[+]** or **[-]** repeatedly to display the desired item.
- Press **[ERASE]**.
- Press **[SET]**.

3.2 Making a phone call using the navigator directory

Before using this feature, program the desired names and telephone numbers into the navigator directory (page 25).

- Keep the front cover page open for button locations.
- 1 Press [**▶**].
 - 2 Press [**+**] or [**-**] repeatedly to display the desired item.
 - 3 Press [**DIGITAL SP-PHONE**] or lift the handset.
 - The unit will start dialing automatically.

To search for a name by initial

Example: "LISA"

1. Press [**▶**].
2. Press [**+**] or [**-**] to initiate the navigator directory.
3. Press [**5**] repeatedly to display any name with the initial "L" (see the character table, page 22).
 - To search for symbols (not letters or numbers), press [*****].
4. Press [**-**] repeatedly to display "LISA".
 - To stop the search, press [**STOP**].
 - To dial the displayed number, press [**DIGITAL SP-PHONE**] or lift the handset.

Speakerphone operation

- Use the speakerphone in a quiet room.
- Adjust the speaker volume using [**+**] or [**-**].

3.3 Recording a telephone conversation

You can record a telephone conversation. This conversation can be played back later, either directly (page 43) or remotely (page 44).

- Keep the front cover page open for button locations.
- 1 During a telephone conversation, press [**RECORD**].
 - "2WAY RECORDING" will be displayed.
 - 2 To stop recording, press [**STOP**] or replace the handset.

Note:

- There may be legal restrictions on recording two-way telephone conversations. Inform the other party that the conversation is being recorded.

3.4 Caller ID service

This unit is compatible with the Caller ID service offered by your local telephone company. To use this unit's Caller ID features, you must subscribe to a Caller ID service.

Change the following ring settings to 2 or more rings beforehand.

- TAM ring setting (feature #06 on page 51) and FAX ring setting (feature #06 on page 51)

3.4.1 How Caller ID is displayed

The calling party's name or telephone number will be displayed after the first ring. You then have the option of whether or not to answer the call.

The unit will automatically store caller information (name, telephone number and the time of the call) of the 30 most recent calls. Caller information is sorted by the most recent to the oldest call. When the 31st call is received, the first call is deleted. Caller information can be viewed on the display one item at a time (page 27). You can print the Caller ID list (page 72).

Note:

- If the unit is connected to a PBX (Private Branch Exchange) system, you may not receive the caller information. Consult your PBX supplier.
- If the unit cannot receive caller information, the following will be displayed:
 "OUT OF AREA": The caller dialed from an area which does not provide Caller ID service.
 "PRIVATE CALLER": The caller requested not to send caller information.

To confirm caller information using the Caller ID list

The unit will store information for the most recent 30 callers.

- To print manually, see page 72.
- To print automatically after every 30 new calls, activate feature #26 (page 52).

3.5 Viewing and calling back using caller information

You can easily view caller information and call back.

Important:

- Calling back will not be possible in the following cases:
 - The telephone number includes data other than numbers (i.e., * or #).
 - The caller information does not include a telephone number.

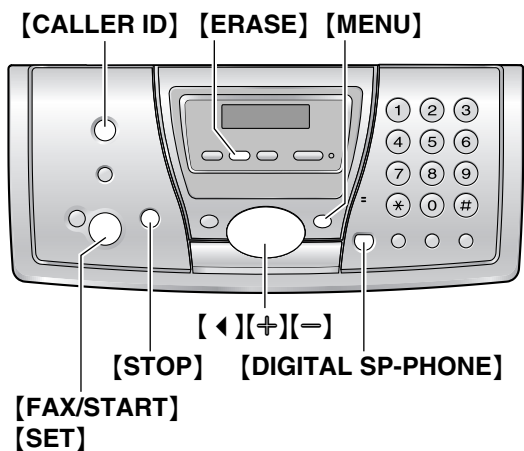

- 1 Press **[CALLER ID]**.
- 2 Press **[+]** to search from the most recent calls.
Press **[-]** to search from the oldest calls.
- 3 Press **[DIGITAL SP-PHONE]** or lift the handset to return the call.
 - The unit will start dialing automatically.
 - To send a fax insert the document FACE DOWN and press **[FAX/START]**.

To change the display of the caller information

Press **[CALLER ID]** repeatedly after step 2 on page 27.

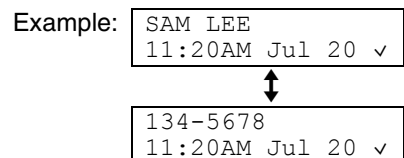

- Check mark (✓) on the display means the call has already been viewed or answered.

3. Telephone

Display while viewing

- When the unit could not receive a name, the display will show "NO NAME RCVD".
- When no calls have been received, the display will show "NO CALLER DATA".

To edit a telephone number for calling back

Press [**✳**] repeatedly after step 2. Each time you press [**✳**], the telephone number will be changed as follows:

- ① 1 - Area code - Local telephone number ("1" added)
- ② Local telephone number only (area code omitted)
- ③ Area code - Local telephone number
- ④ 1 - Local telephone number ("1" added and area code omitted)

To stop viewing

Press [**STOP**] after step 2 on page 27.

3.5.1 Erasing all caller information

- 1 Press [**MENU**] repeatedly to display "CALLER SETUP".
- 2 Press [**SET**].
- 3 Press [**SET**].
 - To cancel erasing, press [**STOP**] 3 times.
- 4 Press [**SET**].
- 5 Press [**STOP**].

3.5.2 Erasing specific caller information

- 1 Press [**CALLER ID**].
- 2 Press [**+**] or [**-**] repeatedly to display the desired item.
- 3 Press [**◀**].
 - To cancel erasing, press [**STOP**] 2 times.
- 4 Press [**SET**].
 - To erase other items, repeat step 2 to 4.
- 5 Press [**STOP**].

Another method to erase a specific caller information

1. Press [**CALLER ID**].
2. Press [**+**] or [**-**] repeatedly to display the desired item.

3. Press [**ERASE**].
 - To erase other items repeat step 2 to 3.
4. Press [**STOP**].

3.6 Storing caller information into the navigator directory

- Keep the front cover page open for button locations.

Important:

- **This feature is not available in the following cases.**
 - The telephone number includes data other than numbers (i.e., * or #).
 - The caller information does not include a telephone number.

- 1 Press **[CALLER ID]**.
- 2 Press **[+]** or **[-]** repeatedly to display the desired item.
- 3 Press **[MENU]**.
- 4 Press **[SET]**.
- 5 Press **[SET]**.

Note:

- You can confirm the stored items in the telephone number list (page 72).
- The unit can only store a name of up to 10 characters long.
- To edit a name and number, see page 25.

3. Follow the voice guide.

- After transmission, the voice guide will turn OFF automatically.

Sending report for confirmation

A sending report provides you with a printed record of transmission results. To use this feature, activate feature #04 (page 51). For an explanation of error messages, see page 58.

Journal report

A journal report provides you with a printed record of the 30 most recent faxes. To print manually, see page 72. To print automatically after every 30 new fax communications, activate feature #22 (page 52). For an explanation of error messages, see page 58.

4.2 Documents you can send

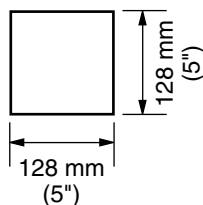
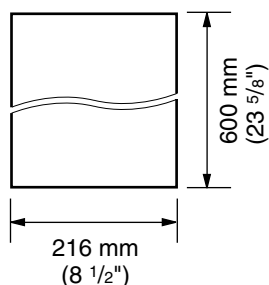
Minimum document size**Maximum document size****Effective scanning area**

- Shaded area (①) will be scanned.

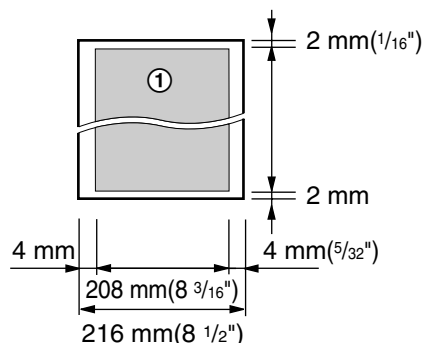
**Document weight**

- Single sheet: 45 g/m² to 90 g/m² (12 lb. to 24 lb.)
- Multiple sheets: 60 g/m² to 80 g/m² (16 lb. to 21 lb.)

Note:

- Remove clips, staples or other fasteners.
- Do not send the following types of documents: (Use copies for fax transmission.)
 - Chemically treated paper such as carbon or carbonless duplicating paper
 - Electrostatically charged paper
 - Badly curled, creased or torn paper
 - Paper with a coated surface
 - Paper with a faint image
 - Paper with printing on the opposite side that can be seen through the other side, such as newsprint.
- Check that ink, paste or correction fluid has dried completely.
- To transmit a document with a width of less than 210 mm (8 1/4"), we recommend using a copy machine to copy the original document onto A4 or letter-sized paper, then transmitting the copied document.

4.3 Sending a fax using the navigator directory

Before using this feature, program the desired names and telephone numbers into the navigator directory (page 25).

- Keep the front cover page open for button locations.
- 1 Adjust the width of the document guides to fit the actual size of the document.
 - 2 Insert the document (up to 10 pages) FACE DOWN until a single beep is heard and the unit grasps the document.
 - If the document guides are not adjusted to fit the document, re-adjust them.
 - 3 If necessary, press **[+]** or **[-]** repeatedly to select the desired resolution (page 30).
 - 4 Press **[▶]**.
 - 5 Press **[+]** or **[-]** repeatedly to display the desired item and press **[FAX/START]**.

Fax auto redial

If the line is busy or if there is no answer, the unit will automatically redial the number.

- To cancel redialing, press **[STOP]**.

If your unit does not send a fax

- Confirm that you have entered the number correctly, and that the number is a fax number.
- Confirm that the other party's fax machine is answering by turning on the connecting tone feature (feature #76, page 54).

4.4 Broadcast transmission

By programming items from the navigator directory (page 25) into the broadcast memory, you can send the same document to multiple parties (up to 20). Your programmed items will remain in the broadcast memory, allowing frequent re-use. See page 33 for broadcast transmission instructions.

- Keep the front cover page open for button locations.

4.4.1 Programming items into the broadcast memory

- 1 Press **[MENU]** repeatedly to display "DIRECTORY SET".
- 2 Press **[#]**.
 - The number in brackets indicates the number of registered items.
- 3 Press **[+]** or **[-]** repeatedly to display the desired item.
- 4 Press **[SET]**.
 - To program other items, repeat steps 3 and 4 (up to 20 items).
- 5 Press **[SET]**.

Note:

- If you program the wrong item, press **[STOP]** after step 4 to erase the item.
- Confirm the stored items by printing a broadcast programming list (page 72).

4.4.2 Adding a new item into the broadcast memory

After initial programming, you can add new items (up to a combined total of 20).

- 1 Press **[▶]**.
- 2 Press **[+]** or **[-]** repeatedly to display "<BROADCAST>".
- 3 Press **[MENU]**.
- 4 Press **[*]**.
- 5 Press **[+]** or **[-]** repeatedly to display the desired item you want to add.
- 6 Press **[SET]**.
 - To add other items, repeat steps 5 and 6 (up to 20 items).
- 7 Press **[STOP]**.

4.4.3 Erasing a stored item from the broadcast memory

- 1 Press [▶].
- 2 Press [⊕] or [⊖] repeatedly to display "<BROADCAST>".
- 3 Press [MENU].
- 4 Press [⊞].
- 5 Press [⊕] or [⊖] repeatedly to display the desired item you want to erase.
 - To cancel erasing, press [STOP].
- 6 Press [SET].
- 7 Press [SET].
 - To erase other items, repeat steps 5 to 7.
- 8 Press [STOP].

4.4.4 Sending the same document to pre-programmed parties

- 1 Insert the document FACE DOWN.
- 2 If necessary, press [⊕] or [⊖] repeatedly to select the desired resolution (page 30).
- 3 Press [BROADCAST].
 - The document will be fed into the unit and scanned into memory. The unit will then transmit the data to each item, calling each number sequentially.
 - After transmission, the stored document will be erased automatically, and the unit will automatically print a broadcast sending report.

Note:

- If you select "FINE", "SUPER FINE" or "PHOTO" resolution, the number of pages that the unit can transmit will decrease.
- If the document exceeds the memory capacity, sending will be canceled.
- If a party is busy or does not answer, it will be skipped and redialed later.

To send the same document to a one-time group of parties

You can also select a one-time group of parties to send the same document to. After transmission, this group will be deleted.

1. Insert the document.
2. Press [▶].
3. Press [⊕] or [⊖] repeatedly to display "<ONE TIME BROAD>".

4. Press [SET] to start programming the items you want to transmit to.
5. Press [⊕] or [⊖] repeatedly to display the desired item.
6. Press [SET].
 - To program other items, repeat steps 5 and 6 (up to 20 items).
7. Press [SET] to start transmission to the programmed items.

To cancel broadcast transmission

1. Press [STOP] while the unit displays "BROADCASTING".
 - The display will show "SEND CANCELED?".
2. Press [SET].

4.5 Receiving a fax manually – [AUTO ANSWER] OFF

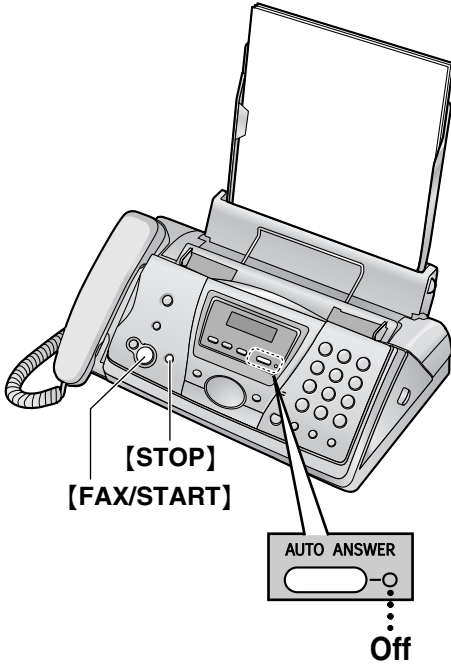

4.5.1 Activating TEL mode

Set the fax machine to TEL mode by pressing [AUTO ANSWER] repeatedly to display the following.

TEL MODE

- The [AUTO ANSWER] indicator turns OFF.

How to receive calls

- 1 Lift the handset to answer the call.
- 2 When:
 - document reception is required,
 - a fax calling tone (slow beep) is heard, or
 - no sound is heard,press [FAX/START].

CONNECTING.....

- The unit will start fax reception.

- 3 Replace the handset.

To stop receiving

Press [STOP].

Extension telephone

You can receive fax documents using an extension telephone.

1. When the extension telephone rings, lift the handset of the extension telephone.
2. When:
 - document reception is required,
 - a fax calling tone (slow beep) is heard, or
 - no sound is heard,press [*][#][9] (default fax activation code) **firmly**.
3. Replace the handset.
 - The fax machine will start reception.

Note:

- To receive fax documents using the extension telephone, you must set the remote fax activation to ON (feature #41, page 53) beforehand. The default setting is "ON".

4.6 Receiving a fax automatically – [AUTO ANSWER] ON

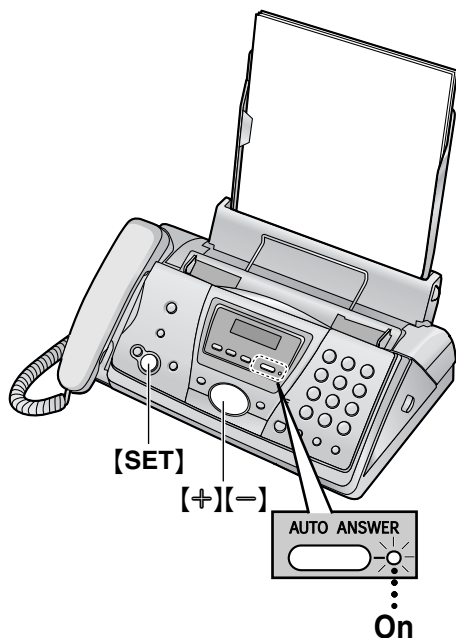

4.6.1 Activating FAX ONLY mode

- 1 Set feature #77 to "FAX ONLY" (page 54) beforehand.
- 2 Press [AUTO ANSWER] repeatedly to display the following.

FAX ONLY MODE 3 RINGS

- The display will show the ring setting in FAX ONLY mode. If you wish to change it, press [+] or [−] repeatedly to display the desired setting, and press [SET].
- The [AUTO ANSWER] indicator turns ON.

How to receive calls

When receiving calls, the unit will automatically answer all calls and only receive fax documents.

4.6.2 Activating TAM/FAX mode (Telephone Answering Machine/Fax mode)

- 1 Set feature #77 to "TAM/FAX" (page 54) beforehand.

- 2 Press [AUTO ANSWER] repeatedly to display the following.

TAM/FAX MODE 2 RINGS

- The unit will play the pre-recorded greeting message.
- The display will show the ring setting in TAM/FAX mode. If you wish to change it, press [+] or [−] repeatedly to display the desired setting, and press [SET].
- You can adjust the speaker volume after changing the ring setting. Press [+] or [−] while listening to the greeting message.
- The [AUTO ANSWER] indicator turns ON.
- The remaining time for recording incoming messages will be displayed.

Note:

- The maximum incoming message recording time can be changed (feature #10, page 51).
- While an incoming call is being recorded, you can monitor it through the speaker. If this feature is not required, set feature #67 to OFF (page 54).

How to receive calls

When receiving calls, the unit works as a telephone answering machine and fax.

- If the call is a phone call, the unit will record a voice message automatically.
- If a fax calling tone is detected, the unit will receive a fax automatically.

Receiving a voice message and fax document in one call

The caller can leave a voice message and send a fax document during the same call. Inform the caller of the following procedure beforehand.

1. The caller calls your unit.
 - The answering machine will answer the call.
2. The caller can leave a message after the greeting message.
3. The caller presses [*][9].
 - The unit will activate the fax function.
4. The caller presses the start button to send a document.

Ring setting in TAM/FAX mode

You can choose from "1", "2" (default), "3", "4", "TOLL SAVER" and "RINGER OFF". This setting can be changed by feature #06 on page 51.

- "TOLL SAVER": When you call the unit from a remote location to listen to new messages (page 44), the number of times the unit rings

will tell you if there are any new voice messages. The unit will answer on the 2nd ring when there is at least one new recorded message. The unit will answer on the 4th ring when there are no new recorded messages. If you do not want to listen to old messages, hang up when you hear the 3rd ring, because it indicates there are no new messages. You will not pay for the call.

- “RINGER OFF”: The unit will answer without ringing.
- If you subscribe to a Caller ID service, set to 2 or more rings.

4.7 Junk fax prohibitor (preventing fax reception from undesired callers)

If you subscribe to caller ID service, this feature prevents fax reception from calls that do not show caller information.

Additionally, faxes originating from numbers that match a programmable junk fax prohibitor list will not be accepted by the fax machine (page 36).

- Keep the front cover page open for button locations.

Important:

- **This feature does not work when:**
 - the unit is set to the TEL mode, or
 - manual reception is performed.

4.7.1 Activating the junk fax prohibitor

- 1 Press **[MENU]** repeatedly to display “JUNK FAX PROH.”.
- 2 Press **[▶]**.
- 3 Press **[+]** or **[–]** repeatedly to select “ON”.
- 4 Press **[SET]**.
- 5 Press **[STOP]**.
 - While the junk fax prohibitor is activated, “JUNK FAX ON” is displayed.

4.7.2 Programming undesired callers

You can register up to 10 undesired numbers from the Caller ID list (page 27) if you do not wish to receive faxes from them.

- 1 Press **[MENU]** repeatedly to display “JUNK FAX PROH.”.
- 2 Press **[▶]** repeatedly to display “JUNK LIST SET”.
- 3 Press **[SET]**.
- 4 Press **[+]** or **[–]** repeatedly to display the item you wish to prevent the fax reception from.
- 5 Press **[SET]**.
 - To program other items, repeat steps 4 to 5.
- 6 Press **[STOP]** to exit the program.

Note:

- If there is no space to store new items, “LIST FULL” is displayed in step 3 or step 5. Erase unnecessary items.

To display the junk fax prohibitor list

1. Press **[MENU]** repeatedly to display “JUNK FAX PROH.”.
2. Press **[▶]** repeatedly to display “JUNK LIST DISP.”.
3. Press **[SET]**.
4. Press **[+]** or **[−]** repeatedly to display the item.
5. To stop viewing, press **[STOP]**.
6. To exit the list, press **[STOP]**.

To print the junk fax prohibitor list

1. Press **[MENU]** repeatedly to display “JUNK FAX PROH.”.
2. Press **[▶]** repeatedly to display “JUNK LIST PRINT”.
3. Press **[SET]**.
4. Press **[STOP]** to exit the list.

To erase an item from the junk fax prohibitor list

1. Press **[MENU]** repeatedly to display “JUNK FAX PROH.”.
2. Press **[▶]** repeatedly to display “JUNK LIST DISP.”.
3. Press **[SET]**.
4. Press **[+]** or **[−]** repeatedly to display the desired item.
5. Press **[◀]**.
 - To cancel erasing, press **[STOP]**, then press **[MENU]**.
6. Press **[SET]**.
 - The item is erased.
7. Press **[MENU]** to exit the list.

5.1 Distinctive Ring service from your phone company

This service is convenient if you wish to have a different number for your fax machine and telephone, even when you use them on a single telephone line.

Distinctive Ring is a service offered by your local telephone company which allows you to use several telephone numbers on one telephone line. When a call is made to one of your phone numbers, the telephone company sends a ring pattern to your telephone line to indicate which number the call is intended for. By setting up this unit for Distinctive Ring, you can make the fax machine automatically start fax reception when a call comes to the fax number.

To use this service, you must subscribe to the Distinctive Ring service offered by your local telephone company.

5.2 Using two or more phone numbers on a single telephone line

5.2.1 Activating the Distinctive Ring feature

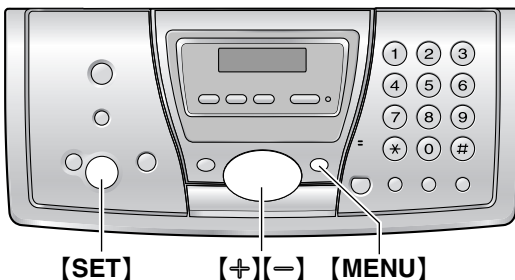

- 1 Press **[MENU]**.
- 2 Press **[*]**, then **[3][1]**.
- 3 Press **[+]** or **[-]** repeatedly to select "ON".
- 4 Press **[SET]**.
- 5 Press **[MENU]**.

How to receive calls

If the incoming call is for the fax number, the fax machine will ring with the assigned ring pattern and automatically start fax reception.

If the incoming call is for the phone number:

- the fax machine will keep on ringing in TEL mode.
- the fax machine will record a voice message in TAM/FAX mode.
- fax communication will be attempted in FAX ONLY mode.





5.3 Using three or more phone numbers on a single telephone line

You may wish to use three or more phone numbers for a single telephone line to distinguish which number the call was addressed to. A different ring pattern must be assigned for each number.

Example: Using three phone numbers

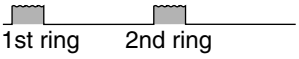
Telephone number	Ring pattern	Use
012 1234	Standard ring	Personal
012 5678	Double ring	Business
012 9876	Triple ring	Fax

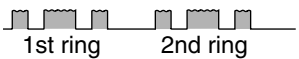
To use one phone number for the fax, program the ring pattern assigned for the fax in feature #32 (page 39). In the example, the ring pattern assigned for fax is a triple ring, so you should program "C" (triple ring).

Ring pattern	Settings in feature #32
Standard ring (one long ring)  1st ring 2nd ring	A
Double ring (two short rings)  1st ring 2nd ring	B
Triple ring (short-long-short rings)  1st ring 2nd ring	C
Other triple ring (short-short-long rings)  1st ring 2nd ring	D

5.4 Programming the ring pattern assigned for fax

- Keep the front cover page open for button locations.
- 1 Set feature #31 to "ON" (page 38).
 - 2 Press **[MENU]**.
 - 3 Press **[#]**, then **[3][2]**.
 - 4 Press **[+]** or **[-]** repeatedly to select the ring pattern assigned for fax.
 - A:** Standard ring (one long ring)
 - B:** Double ring (two short rings)
 - C:** Triple ring (short-long-short-rings)
 - D:** Other triple ring (short-short-long rings)
 - B-D (default setting):** For the ring pattern of B, C and D
 - 5 Press **[SET]**.
 - 6 Press **[MENU]**.

6.1 Making a copy

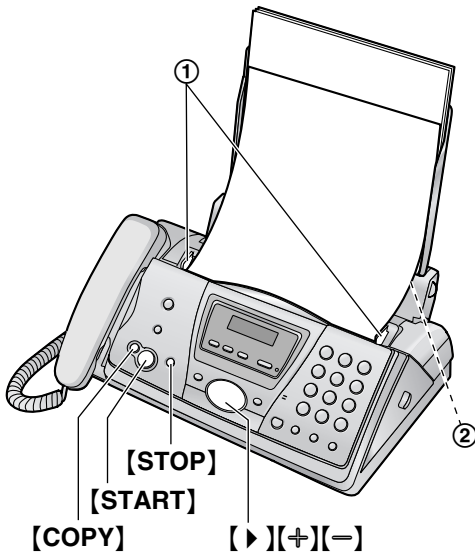

- 1 Adjust the width of the document guides (①) to fit the actual size of the document.
- 2 Insert the document (up to 10 pages) FACE DOWN (②) until a single beep is heard and the unit grasps the document.
 - If the document guides are not adjusted to fit the document, re-adjust them.
- 3 If necessary, press **[+]** or **[-]** repeatedly to select the desired resolution.
- 4 Press **[COPY]**.
 - If necessary, enter the number of copies (up to 30).
- 5 Press **[START]**, or wait for 15 seconds.
 - The unit will start copying.

Note:

- Any transmittable document can be copied (page 31).

To select the resolution

Select the desired resolution according to the type of document.

- "FINE": For printed or typewritten originals with small printing.
- "SUPER FINE": For originals with very small printing.
- "PHOTO": For originals containing photographs, shaded drawings, etc.
- If you select "STANDARD", copying will be done using "FINE" mode.

Quick scan feature

This feature is helpful when you want to copy the document, then remove it for other uses. To use this feature, activate feature #34 (page 52) beforehand.

- The document will be fed into the unit and scanned into memory. The unit will then print the data.
- If the document exceeds the memory capacity, copying of the exceeded document will be canceled and this feature will be turned OFF automatically.

To stop copying

Press **[STOP]**.

6.1.1 More copying features

To enlarge a document

1. Insert the document, then press **[COPY]**.
2. Press **[▶]**.
3. Press **[+]** repeatedly to select "150%" or "200%", then press **[START]**.
 - The unit will only enlarge the center of the upper part of the document. To make an enlarged copy of the bottom of the document, turn the document around, and then make a copy.

Example: 150% enlarged copy

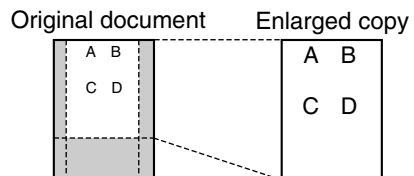

To reduce a document

1. Insert the document, then press **[COPY]**.
2. Press **[▶]**.
3. Press **[-]** repeatedly to select "92%", "86%" or "72%", then press **[START]**.

Setting	Recording paper size	Original document size
100% (default)	Letter	Letter
92%	Letter	A4
86%	Letter	A4
72%	Letter	Legal

Letter = 216 mm × 279 mm (8¹/₂" × 11")

Legal = 216 mm × 356 mm (8¹/₂" × 14")

A4 = 210 mm × 297 mm (8¹/₄" × 11¹¹/₁₆")

Note:

- If the appropriate reduction rate is not selected, the document may be divided and the top of the second sheet will be deleted.
- If the image at the bottom of the document is not copied when you copy a document that is the same length as the recording paper, try 92% or 86%.

To collate multiple copies

The unit can collate multiple copies in the same order as the original document pages.

1. Insert the document, then press **[COPY]**.
2. Enter the number of copies (up to 30).
3. Press **[▶]** 2 times to display "COLLATE OFF".
4. Press **[+]** or **[-]** repeatedly to display "COLLATE ON".
5. Press **[START]**.

Example: Making 2 copies of a 4-page original document

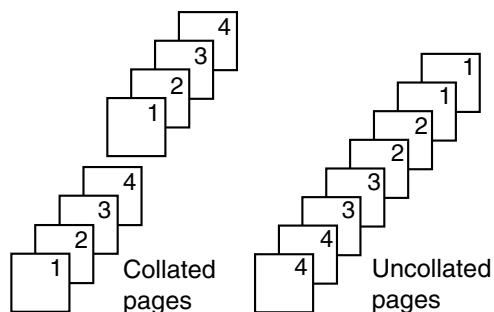

Note:

- The unit will store the documents into memory while collating the copies. If memory becomes full while storing, the unit will only print out the stored pages.
- After copying, the collating feature will turn OFF automatically.
- If the unit has run out of recording paper, the unit will scan the document but will not print, and also the data will not be stored in the memory. Re-install paper, press **[START]**, then try copying again.

7.1 Recording your greeting message

You can record your own greeting message for TAM/FAX mode, for a maximum of 16 (default) or 60 seconds in length. We recommend you record a message of less than 12 seconds to make it easier to receive faxes.

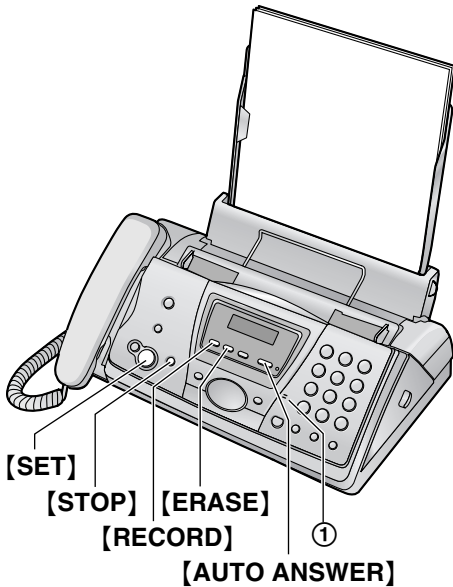

- 1 Set feature #77 to "TAM/FAX" (page 54) beforehand.
- 2 Press **[RECORD]** 2 times.
- 3 Press **[SET]**.
 - A long beep will sound.
- 4 Speak clearly about 20 cm (8 inches) away from the microphone (①).
 - The display will show the remaining recording time.
- 5 When finished recording, press **[STOP]**.
 - The unit will repeat your message.

Note:

- You can choose 60 seconds for your TAM/FAX greeting message (feature #54, page 54).
 - If you change the maximum greeting message time to 60 seconds, we recommend that you tell the caller in your TAM/FAX greeting message to press **[*][9]** before starting fax transmission.
 - If you change the maximum greeting message time from 60 seconds to 16 seconds, your greeting message will be

deleted. When a call is received, the pre-recorded greeting message will be played.

Checking the greeting message

1. Set feature #77 to "TAM/FAX" (page 54) beforehand.
2. Press **[AUTO ANSWER]** repeatedly to display "TAM/FAX MODE".
 - The unit will play the greeting message.

7.1.1 Erasing your recorded greeting message

- 1 Set feature #77 to "TAM/FAX" (page 54) beforehand.
- 2 Press **[ERASE]** 2 times.
- 3 Press **[SET]**.
 - To cancel erasing, press **[STOP]**.
- 4 Press **[SET]**.

Note:

- If you erase your TAM/FAX greeting message, the pre-recorded greeting message will be played when a call is received.

7.2 Leaving a message for others or yourself

To leave a private message for yourself or someone else, you can record a voice memo. This memo can be played back later, either directly or remotely.

- Keep the front cover page open for button locations.
- 1 Press **[RECORD]**.
 - 2 Press **[SET]**.
 - A long beep will sound.
 - 3 Speak clearly about 20 cm (8 inches) away from the microphone.
 - 4 When finished recording, press **[STOP]**.

7.3 Listening to recorded messages

The display will show the total number of recorded messages.

When the unit has recorded new voice messages:

- The **[AUTO ANSWER]** indicator will flash when AUTO ANSWER is turned ON.
- The total number of recorded messages will flash on the display.

Example: 

- The unit will beep slowly if the message alert feature is activated (feature #42, page 53).

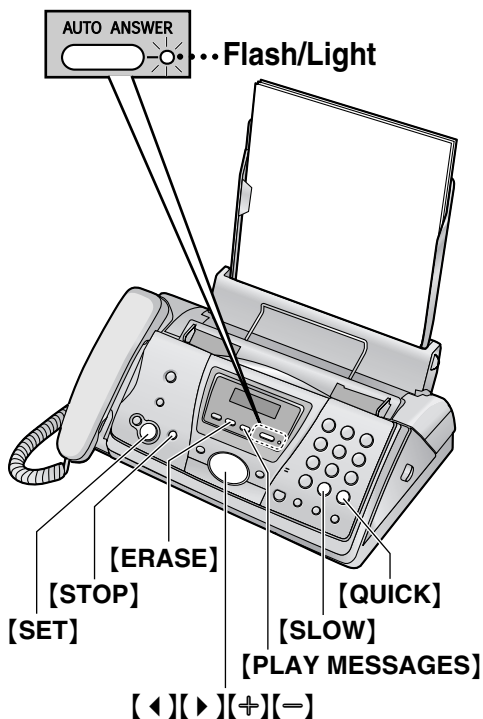

Press **[PLAY MESSAGES]**.

- Only the new recorded messages will be played.
- Adjust the speaker volume using **[+]** or **[-]**.
- After playing back all of the new messages, the **[AUTO ANSWER]** indicator will stop flashing but will remain lit up when AUTO ANSWER is turned ON. If you press **[PLAY MESSAGES]** at this time, all the recorded messages will be played.

Note:

- The total recording time of all messages (greeting, incoming and memo) is **about 18 minutes**. If messages are recorded in noisy rooms, the time may be shortened.

To repeat a message

Press **[◀]** while listening to the message.

- If you press **[◀]** within 5 seconds of the beginning of the message, the previous message will be played.
- To play back a specific message, press **[◀]** or **[▶]** and search for the message you want to listen to.

To skip a message

Press **[▶]** to play the next message.

To stop playback temporarily

Press **[STOP]**.

- If you press **[PLAY MESSAGES]** within 1 minute, the unit will resume playing the rest of the messages.

Voice time/day stamp

During playback, a synthesized voice will announce the day of the week and time that each message was recorded.

To change the playback speed

Press **[QUICK]** to play messages at one and a half times the original speed. Press **[SLOW]** to play messages at half the original speed.

- To return to the original speed, press either **[QUICK]** or **[SLOW]** again during quick or slow playback.

7.3.1 Erasing recorded messages

To erase a specific message

Press **[ERASE]** while listening to the message you want to erase.

To erase all the messages

- 1 Press **[ERASE]**.
- 2 Press **[SET]**.
 - To cancel erasing, press **[STOP]**.
- 3 Press **[SET]** again.

Helpful hints:

- Messages recorded in the voice mailbox will not be erased.

7.4 Operating from a remote location

You can call your unit from a remote location and access the answering machine.

Important:

- Program the remote operation ID beforehand (feature #11, page 51).
- Set the unit to TAM/FAX mode before going out (page 35).
- Use a touch tone telephone for remote operations.

Helpful hints:

- When you press a key, press firmly.
- Please make a copy of the following table, and carry it with you when you go out.

Answering machine remote operation			
1. Call your unit.		[2]	Skips a message
2. Enter the remote operation ID during the TAM/FAX greeting message.		[4]	New message playback
3. Enter the remote command key within 10 seconds.		[5]	All message playback
<ul style="list-style-type: none"> • To record a message in a mailbox, call your unit, press [*] and the mailbox no. (1 or 2), then leave a message. • To retrieve messages from a mailbox, call your unit, press [*] and the mailbox no. (1 or 2), enter the mailbox password, then press the remote command key. 		[6]	Room monitor
		[7]	Re-records the greeting message
		[9]	Stops re-recording of the greeting message
		[*][4]	Erases a specific message
		[*][5]	Erases all messages
		[8][0]	Changes to TEL mode
		[8][1]	Turns ON message transfer
Key	Remote command	[8][2]	Turns OFF message transfer
[0]	Skips the greeting message	[8][3]	Turns ON pager call
[1]	Repeats a message	[8][4]	Turns OFF pager call

7.4.1 Listening to recorded messages

- 1 Call your unit.
- 2 Enter the remote operation ID during the TAM/FAX greeting message.
- 3 Start remote operations.
When there are new recorded messages
 The voice guide will tell you the number of new messages and they will be played automatically.

When there are no new messages

Voice guide:

"No new messages."

Wait for 4 seconds or press [5] to listen to all the messages.

When voice memory is full

Voice guide:

"Sorry, no more memory. Please erase unnecessary messages."

Erase unnecessary messages.

7.4.2 Remote operations using the remote command key

[1]: repeats a message. If you press this key within 5 seconds of the beginning of a message, the previous message will be played.

[2]: skips a message.

[4]: plays back only the new messages.

[5]: plays back all the messages.

Note:

- If you do not enter a remote command key within 10 seconds after the last operation, the unit will ask you to leave a marker message (page 45).

7.4.3 Other remote operations

Erasing a specific message

Press **[*][4]** while listening to the message you want to erase.

Voice guide:

"The message has been erased."

- A long beep will sound. The unit will then play back the next message.

Erasing all the messages

Press **[*][5]** to erase all the messages.

Voice guide:

"All messages have been erased."

- A long beep will sound.

Monitoring the room

Press **[6]** to monitor the sound for about 30 seconds in the room where the unit is installed.

- After 30 seconds, a beep will sound. To continue monitoring, press **[6]** again within 10 seconds.

Recording a marker message

After playing back the messages, you can leave an additional message.

1. Wait for the voice guide.

Voice guide:

"All messages have been played."

2. Wait about 10 seconds.

Voice guide:

"Please leave your name and message after the beep."

3. Leave a message after the beep.

Re-recording your greeting message

You can change the TAM/FAX greeting message.

1. Press **[7]** to start recording.
 - A long beep will sound.
2. Speak clearly for up to 16 seconds.
 - If you pause for over 2 seconds, 6 beeps will sound and the recording will stop. Repeat from step 1 within 10 seconds.
3. When finished recording, press **[9]**.
 - The new greeting message will be played.

Skipping the greeting message

Press **[0]** during the greeting message playback.

- The unit will skip the rest of the greeting message.

Turning message transfer ON or OFF

You must program a transfer telephone number beforehand (feature #60, page 54).

Press **[8][1]** to turn ON the message transfer.

Voice guide example:

"Message transfer is set. Transfer phone number is 123..."

Press **[8][2]** to turn OFF the message transfer.

Voice guide:

"Message transfer is off."

Turning pager call ON or OFF

You must program a pager number beforehand (feature #70, page 54).

Press **[8][3]** to turn ON the pager call.

Voice guide example:

"Pager call is set. Pager number is 098765432."

Press **[8][4]** to turn OFF the pager call.

Voice guide:

"Pager call is off."

Changing the receive mode

Press **[8][0]** to change the receive mode from TAM/FAX to TEL.

- You cannot return to TAM/FAX mode in the same call. To return to TAM/FAX mode, see the following.

Setting to TAM/FAX mode from TEL mode

1. Call your unit and wait for 10 rings.
 - The answering machine will temporarily answer the call.
2. Enter the remote operation ID during the greeting message.
 - A long beep will sound, and your unit will switch to TAM/FAX mode.
3. Hang up the handset.

7.5 Allowing callers to leave private messages

This unit has two private mailboxes. A caller can leave a private message in a specific mailbox. Only the person who knows the password can retrieve a message from a mailbox. This feature is useful when you share this unit with other people.

7.5.1 To use a mailbox

- 1 Record your TAM/FAX greeting message (page 42).
Sample message: *"This is (your name). We are unable to answer right now. To send a fax, start transmission. To leave a message, speak after the beep. To leave a private message, press [*] and the desired mailbox number [1] or [2]. Thank you."*
- 2 Record your mailbox greeting message if necessary (page 46).
- 3 Change the mailbox password if necessary.
 - For mailbox 1 password, see feature #51 (page 53).
 - For mailbox 2 password, see feature #52 (page 54).
- 4 Set the unit to TAM/FAX mode (page 35).

7.5.2 Leaving messages in a mailbox

- 1 Call your unit from a remote touch tone telephone.
 - The TAM/FAX greeting message will be played.
- 2 Press [*] and the desired mailbox number ([1] or [2]).
 - A mailbox greeting message will be played.
- 3 After the beep, leave a message.

Note:

- If the caller does not enter a mailbox number in step 2, the message will be recorded in the common memory.

7.6 Recording your mailbox greeting messages

The recording time of each greeting is limited to 16 seconds for each mailbox.

Sample message: *"This is (personal name). Please leave your name and message after the beep."*

- Keep the front cover page open for button locations.
- 1 Press [MENU].
 - 2 **For mailbox 1:**
Press [⇄], then [5][5].
For mailbox 2:
Press [⇄], then [5][6].
 - 3 Press [+] or [–] repeatedly to select "RECORD".
 - 4 Press [SET].
 - 5 Speak clearly about 20 cm (8 inches) away from the microphone.
 - The display will show the remaining recording time.
 - 6 When finished recording, press [STOP].
 - The unit will repeat your message.
 - 7 Press [MENU].

To check the mailbox greeting message

1. **For mailbox 1:**
Press [MENU], then [⇄][5][5].
For mailbox 2:
Press [MENU], then [⇄][5][6].
2. Press [+] or [–] repeatedly to select "CHECK".
3. Press [SET].
 - The unit will play the message.
4. Press [MENU].

To erase your mailbox greeting message

1. **For mailbox 1:**
Press [MENU], then [⇄][5][5].
For mailbox 2:
Press [MENU], then [⇄][5][6].
2. Press [+] or [–] repeatedly to select "ERASE".
3. Press [SET].

- Your mailbox greeting message will be erased.

4. Press **[MENU]**.

7.7 Listening to recorded mailbox messages

- Keep the front cover page open for button locations.
- 1 Press **[▶]** 2 times.
 - 2 Press **[+]** or **[-]** repeatedly to display the desired mailbox number.
 - 3 Press **[PLAY MESSAGES]**.
If you have programmed your mailbox password, enter it.
 - Only the new recorded messages will be played.
 - If there are no new messages, the unit will play back all the recorded messages.
 - 4 Press **[STOP]** to end the operation.

Note:

- See the following topics on page 43 for details on features that can be used during playback.
 - To repeat a message
 - To skip a message
 - To stop playback temporarily
 - To change the playback speed
 - To erase a specific message

To record a memo message into a mailbox

1. Press **[▶]** 2 times.
2. Press **[+]** or **[-]** repeatedly to display the desired mailbox number.
3. Press **[RECORD]**.
 - A long beep will sound.
4. Speak clearly about 20 cm (8 inches) away from the microphone.
5. When finished recording, press **[STOP]**.

To erase all messages in a mailbox

1. Press **[▶]** 2 times.
2. Press **[+]** or **[-]** repeatedly to display the desired mailbox number.
3. Press **[ERASE]**.
 - To cancel erasing, press **[STOP]**.
4. Press **[SET]**.

7.8 Listening to recorded mailbox messages from a remote location

- 1 Call your unit from a remote touch tone telephone.
- 2 Press [*****] and the desired mailbox number (**[1]** or **[2]**) during TAM/FAX greeting playback.
 - If you have recorded your mailbox greeting message, it will be played.
- 3 Enter the mailbox password (default setting is "555").

Note:

- For details on remote operation, see page 44. Remote commands **[8][1]**, **[8][2]**, **[8][3]**, and **[8][4]** cannot be used.

To listen to messages in another memory after playback

Press [*****] and **[0]** (for the common memory), then enter the remote operation ID.

OR

Press [*****] and the desired mailbox number (**[1]** or **[2]**), then enter the mailbox password.

7.9 Transferring recorded messages to another telephone

This feature allows your unit to call a designated telephone number each time an incoming voice message is recorded. You can retrieve the transferred message via remote operation.

- Keep the front cover page open for button locations.

Important:

- **To use this feature, program the transfer telephone number first (feature #60, page 54) and set the unit to TAM/FAX mode.**

7.9.1 How this feature works

- 1 An incoming voice message is recorded in your unit.
- 2 Your unit calls the transfer telephone number.
- 3 You answer the call with the transfer telephone.
- 4 Your unit will play the pre-recorded transfer greeting message.
 - You can record a transfer greeting message.
- 5 You enter the remote operation ID, and retrieve the message using remote operation (page 44).

Helpful hints:

- Messages recorded in the voice mailbox will not be transferred.

7.9.2 Recording your transfer greeting message

The recording time is limited to 16 seconds.

Sample message: *"This is a transferred message from (your name, business and/or telephone number). Please enter your remote ID for remote operation."*

- 1 Press [**MENU**].
- 2 Press [**⇄**], then **[6][1]**.
- 3 Press [**+**] or [**-**] repeatedly to select "RECORD".
- 4 Press [**SET**].
- 5 Speak clearly about 20 cm (8 inches) away from the microphone.

- The display will show the remaining recording time.
- 6 When finished recording, press **[STOP]**.
 - The unit will repeat your message.
 - 7 Press **[MENU]**.

To check the transfer greeting message

1. Press **[MENU]**, **[⇄][6][1]**.
2. Press **[+]** or **[-]** repeatedly to select "CHECK".
3. Press **[SET]**.
 - The unit will play the message.
4. Press **[MENU]**.

To erase your transfer greeting message

1. Press **[MENU]**, **[⇄][6][1]**.
2. Press **[+]** or **[-]** repeatedly to select "ERASE".
3. Press **[SET]**.
4. Press **[MENU]**.

Note:

- When transferring a call, the pre-recorded transfer greeting message will be played.

Pager call

This feature allows your unit to call your pager when your unit receives an incoming voice message.

1. Press **[MENU]**.
2. Press **[⇄]**, then **[7][0]**.
3. Press **[+]** or **[-]** repeatedly to select "ON".
4. Press **[SET]**.
5. Enter your pager number up to 30 digits.
6. Press **[SET]**.
7. Enter your pager access code up to 10 digits if required.
8. Press **[SET]**.

MSG.=07734

- The default code 07734 will show "Hello!" on your pager.
 - If you want to change this message, enter your message up to 30 digits.
9. Press **[SET]**.
 - The unit will dial the stored number.
 10. Check that your pager received the pager test call.
 11. Press **[DIGITAL SP-PHONE]**.

8.1 Programming

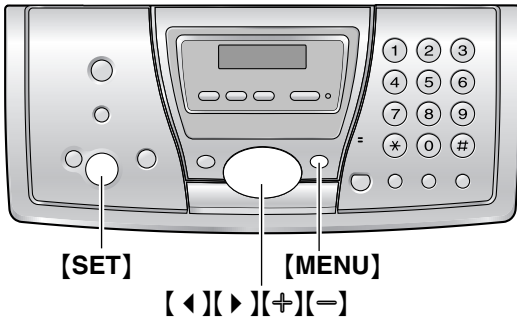

8.1.1 Programming basic features

- 1 Press **[MENU]**.
- 2 Select the feature you wish to program. Press **[◀]** or **[▶]** repeatedly to display the desired feature.
 - The current setting of the feature will be displayed.
- 3 Press **[+]** or **[-]** repeatedly to display the desired setting.
 - This step may be slightly different depending on the feature.
- 4 Press **[SET]**.
 - The setting you selected is set, and the next feature will be displayed.
- 5 To exit programming, press **[MENU]**.

8.1.2 Programming advanced features

- 1 Press **[MENU]**.
- 2 Press **[◀]** or **[▶]** repeatedly to display "ADVANCE SETTINGS".
- 3 Press **[SET]**.
- 4 Select the feature you wish to program. Press **[◀]** or **[▶]** repeatedly to display the desired feature.
 - The current setting of the feature will be displayed.
- 5 Press **[+]** or **[-]** repeatedly to display the desired setting.
 - This step may be slightly different depending on the feature.
- 6 Press **[SET]**.

- The setting you selected is set, and the next feature will be displayed.

- 7 To exit programming, press **[MENU]**.

Programming by entering the program code number directly

You can select a feature by directly entering the program code (# and a 2-digit number) instead of using **[◀]** or **[▶]**.

1. Press **[MENU]**.
2. Press **[#]** and the 2-digit code number (page 51 to page 55).
3. Press **[+]** or **[-]** repeatedly to display the desired setting.
 - This step may be slightly different depending on the feature.
4. Press **[SET]**.
5. To exit programming, press **[MENU]**.

To cancel programming

Press **[MENU]** to exit the program.

8.2 Basic features

Code #00: Setting the Quick Setup

```
QUICK SETUP
PRESS SET
```

See page 15 for details.

Code #01: Setting the date and time

```
SET DATE & TIME
PRESS SET
```

See page 21 for details.

Code #02: Setting your logo

```
YOUR LOGO
PRESS SET
```

See page 22 for details.

Code #03: Setting your fax number

```
YOUR FAX NO.
PRESS SET
```

See page 23 for details.

Code #04: Printing a sending report

```
SENDING REPORT
MODE=ERROR [±]
```

To print a sending report for fax transmission results (page 31).

“ERROR” (default): A sending report will be printed only when fax transmission fails.

“ON”: A sending report will be printed out after every transmission.

“OFF”: Sending reports will not be printed out.

Code #06: Changing the ring setting in TAM/FAX mode (Telephone Answering Machine/Fax mode)

```
TAM RING COUNT
RINGS=2 [±]
```

To change the number of rings before the unit answers a call in TAM/FAX mode. You can select “1”, “2” (default), “3”, “4”, “TOLL SAVER” or “RINGER OFF”. See page 35 for details.

Note:

- Set feature #77 to “TAM/FAX” (page 54) beforehand.

Code #06: Changing the ring setting in FAX ONLY mode

```
FAX RING COUNT
RINGS=3 [±]
```

To change the number of rings before the unit answers a call in FAX ONLY mode.

You can select “1”, “2”, “3” (default) or “4”.

Note:

- Set feature #77 to “FAX ONLY” (page 54) beforehand.

Code #10: Changing the maximum incoming message recording time

```
RECORDING TIME
MODE=VOX [±]
```

“VOX” (default): Unlimited.

“1 MIN”: Up to 1 minute.

Code #11: Setting the remote operation ID

```
REMOTE TAM ID
ID=111
```

1. Press [MENU].
2. Press [⏏], then [1][1].
3. Enter any 3-digit number except a number using 0 or 7.
 - The default ID is “111”.
4. Press [SET].
5. Press [MENU].

Code #13: Setting the dialing mode

```
DIALING MODE
MODE=TONE [±]
```

If you cannot dial, change this setting depending on your telephone line service.

“TONE” (default): For tone dial service.

“PULSE”: For rotary pulse dial service.

Code #17: Setting the ringer pattern

```
RINGER PATTERN
MODE=A [±]
```

You can select “A” (default), “B” or “C”.

8.3 Advanced features

Code #22: Setting the journal report to print automatically

```
AUTO JOURNAL
MODE=ON      [±]
```

“ON” (default): The unit will print a journal report automatically after every 30 new fax communications (page 31).

“OFF”: The unit will not print a journal report, but will keep a record of the last 30 fax communications.

Code #23: Sending documents overseas

```
OVERSEAS MODE
MODE=ERROR   [±]
```

If you cannot send a fax overseas even if the number is correct and the line is connected, activate this feature before starting transmission. This feature improves the reliability by reducing the transmission speed.

“ERROR” (default): When the previous fax transmission fails and you wish to re-send the document.

“NEXT FAX”: This setting is effective only for the next attempted fax transmission. After transmission, the unit will return to the previous setting.

“OFF”: Deactivates this feature.

Note:

- This feature is not available for broadcast transmission.
- The calling charge may be higher than usual.

Code #25: Sending a fax at a specific time

```
DELAYED SEND
MODE=OFF     [±]
```

This feature allows you to take advantage of low-cost calling hours offered by your telephone company. This feature can be set up to 24 hours in advance of the desired time.

To send a document:

1. Insert the document.
2. If necessary, press **[+]** or **[-]** repeatedly to select the desired resolution (page 30).
3. Press **[MENU]**.
4. Press **[#]** then **[2][5]**.
5. Press **[+]** or **[-]** repeatedly to select “ON”.
6. Press **[SET]**.
7. Enter the fax number.

8. Press **[SET]**.

9. Enter the transmission start time.

- Press **[*]** repeatedly to select “AM” or “PM”.

10. Press **[SET]**.

11. Press **[MENU]**.

Note:

- To cancel after programming, press **[STOP]** then **[SET]**.

Code #26: Setting the Caller ID list to print automatically

```
AUTO CALL. LIST
MODE=OFF     [±]
```

“ON”: The unit will print the Caller ID list automatically after every 30 new calls (page 27).

“OFF” (default): The unit will not print the Caller ID list, but keep records of the information for the last 30 callers.

Code #31: Activating the Distinctive Ring feature

```
DISTINCTIVE RING
MODE=OFF     [±]
```

See page 38 for details.

Code #32: Setting the ring pattern for fax (Distinctive Ring feature)

```
FAX RING PATTERN
RING=B-D     [±]
```

See page 39 for details.

Code #34: Setting the quick scan

```
QUICK SCAN
MODE=OFF     [±]
```

This feature is helpful when you want to remove the document for other uses, because the unit will release the document before sending or copying.

“ON”: The unit will scan the document and store it into memory first, then the unit will start sending or copying.

“OFF” (default): Deactivates this feature.

Note:

- If the document exceeds the memory capacity, sending of the whole document or copying of the exceeded document will be canceled and this feature will be turned OFF automatically.

Code #36: Receiving oversized documents

```
RCV REDUCTION
MODE=92%    [±]
```

If the size of the document sent by the other party is as large as, or larger than the recording paper, the unit can reduce the document and print it. Select the desired reduction rate.

Setting	Recording paper size	Original document size
100%	Letter	Letter
92% (default)	Letter	Letter
86%	Letter	A4
72%	Letter	Legal

Note:

- When “100%” is selected, the document may be printed over 2 pages.

Code #39: Changing the display contrast

```
LCD CONTRAST
MODE=NORMAL [±]
```

“NORMAL” (default): For normal contrast.

“DARKER”: Used when the display contrast is too light.

Code #41: Changing the fax activation code

```
FAX ACTIVATION
MODE=ON [±]
```

If you use an extension telephone and wish to use it to receive a fax, activate this feature and program the activation code.

1. Press **[MENU]**.
2. Press **[⇄]**, then **[4][1]**.
3. Press **[+]** or **[-]** repeatedly to select “ON”.
4. Press **[SET]**.
5. Enter your code from 2 to 4 digits, using 0–9, **[*]** and **[⇄]**.
 - The default code is “*#9”.
 - Do not enter “0000”.
6. Press **[SET]**.
7. Press **[MENU]**.

Code #42: Setting the message alert

```
MESSAGE ALERT
MODE=OFF [±]
```

To alert you when a new voice message is recorded. The unit beeps slowly until you listen to the recorded messages.

“ON”: You will be alerted to new messages by a beeping sound.

“OFF” (default): Deactivates this feature.

Code #43: Setting the recording time alert

```
REC. TIME ALERT
MODE=OFF [±]
```

To alert you with beeps when there is less than 60 seconds of remaining recording time. The slow beeps will continue until you erase the recorded messages (page 43, 47).

“ON”: You will be alerted that you have reached the recording time limit by a beeping sound.

“OFF” (default): Deactivates this feature.

Code #44: Setting the memory reception alert

```
RECEIVE ALERT
MODE=ON [±]
```

To alert you with a beeping sound when a received fax document is stored into memory due to some existing problem.

The slow beeps will continue until you clear the printing problem and make sure the unit is supplied with enough paper to print the stored document.

“ON” (default): You will be alerted to a reception problem by a beeping sound.

“OFF”: Deactivates this feature.

Code #46: Setting friendly reception

```
FRIENDLY RCV
MODE=ON [±]
```

To receive a fax automatically when you answer a call and hear a fax calling tone (slow beep).

“ON” (default): You do not have to press

[FAX/START] for fax reception.

“OFF”: You have to press **[FAX/START]** for fax reception.

Code #47: Setting the fax voice guidance

```
FAX GUIDANCE
MODE=ON [±]
```

If you wish to hear voice guidance for fax transmission/reception, activate this feature.

“ON” (default): You will hear voice guidance.

“OFF”: Deactivates this feature.

“ERROR”: To hear voice guidance only when fax transmission/reception fails.

Code #51: Setting the mailbox 1 password

```
BOX1 PASSWORD
ID=
```

To prevent other users from retrieving your messages, program a password for mailbox 1.

1. Press **[MENU]**.
2. Press **[⇄]**, then **[5][1]**.

8. Programmable Features

- Enter a 3-digit number except a number using digits 0 or 7.
 - The default ID is "555".
- Press **[SET]**.
- Press **[MENU]**.

Code #52: Setting the mailbox 2 password

```
BOX2 PASSWORD
ID=
```

To prevent other users from retrieving your messages, program a password for mailbox 2.

- Press **[MENU]**.
- Press **[#]**, then **[5][2]**.
- Enter a 3-digit number except a number using digits 0 or 7.
 - The default ID is "555".
- Press **[SET]**.
- Press **[MENU]**.

Code #54: Changing the recording time for your TAM/FAX greeting message

```
GREETING TIME
MODE=16s [±]
```

"16s" (default): Maximum recording time is 16 seconds.

"60s": Maximum recording time is 60 seconds.
See page 42 for details.

Code #55: Greeting message for mailbox 1

```
BOX1 GREETING
CHECK [±]
```

See page 46 for details.

Code #56: Greeting message for mailbox 2

```
BOX2 GREETING
CHECK [±]
```

See page 46 for details.

Code #60: Setting the message transfer

```
MESSAGE TRANSFER
MODE=OFF [±]
```

To transfer recorded incoming messages to another telephone (page 48), activate this feature and program the transfer telephone number.

- Press **[MENU]**.
- Press **[#]**, then **[6][0]**.
- Press **[+]** or **[-]** repeatedly to select "ON".
- Press **[SET]**.
- Enter the transfer telephone number.

- Press **[SET]**.
- Press **[MENU]**.

Code #61: Checking, recording or erasing the transfer greeting message

```
TRNS-GREETING
CHECK [±]
```

See page 48 for details.

Code #67: Setting the incoming message monitor

```
ICM MONITOR
MODE=ON [±]
```

To hear an incoming message (ICM) from the speaker when the answering machine is recording the message.

"ON" (default): You can monitor the incoming message.

"OFF": Deactivates this feature.

Code #70: Calling your pager

```
PAGER CALL
MODE=OFF [±]
```

See page 49 for details.

Code #76: Setting the connecting tone

```
CONNECTING TONE
MODE=ON [±]
```

If you often have trouble when sending faxes, this feature allows you to hear connecting tones; fax tone, ring back tone and busy tone. You can use these tones to confirm the status of the other party's machine.

"ON" (default): You will hear connecting tones.

"OFF": Deactivates this feature.

Note:

- If the ring back tone continues, the other party's machine may not be a facsimile or may have run out of paper. Check with the other party.
- The connecting tone volume cannot be adjusted.

Code #77: Changing the receiving mode in the AUTO ANSWER setting

```
AUTO ANSWER
MODE=TAM/FAX [±]
```

"TAM/FAX" (default): Telephone Answering Machine/Fax mode (page 35)

"FAX ONLY": Facsimile only mode (page 35)

Code #80: Resetting advanced features to their default settings

SET DEFAULT RESET=NO [±]

To reset the advanced features:

1. Press **[MENU]**.
2. Press **[#]**, then **[8][0]**.
3. Press **[+]** or **[-]** repeatedly to select "YES".
4. Press **[SET]**.
5. Press **[SET]** again.
6. Press **[MENU]**.

8.4 Direct commands for programming features

You can also select the desired setting by directly entering the program code (# and a 2-digit number) and direct command.

For more details on the features, see page 51 to page 55.

- 1 Press **[MENU]**.
- 2 Press **[#]** and the 2-digit code number.
- 3 Press the desired direct command, using the dial keypad, to display the desired setting.
 - This step may be slightly different depending on the feature.
- 4 Press **[SET]**.
- 5 To exit programming, press **[MENU]**.

8.4.1 Program code and direct command button

[#][0][0] Quick Setup

- **[1]**: "TAM/FAX" (default)
- **[2]**: "DIST. RING"
- **[3]**: "TEL ONLY"
- **[4]**: "FAX ONLY"
- Press **[SET]** 2 times before pressing the direct command button.

[#][0][1] Date and time

- Enter the date and time using the dial keypad (see page 21 for details).

[#][0][2] Your logo

- Enter your logo using the dial keypad (see page 22 for details).

[#][0][3] Your fax number

- Enter your fax number using the dial keypad (see page 23 for details).

[#][0][4] Sending report

- **[1]**: "ON"
- **[2]**: "OFF"
- **[3]**: "ERROR" (default)

[#][0][6] FAX ring count

- **[1]**: "1"
- **[2]**: "2"
- **[3]**: "3" (default)
- **[4]**: "4"

8. Programmable Features

[*][0][6] TAM ring count

- [1]: "1"
- [2]: "2" (default)
- [3]: "3"
- [4]: "4"
- [5]: "TOLL SAVER"
- [6]: "RINGER OFF"

[*][1][0] Recording time for an incoming message

- [0]: "VOX" (default)
- [1]: "1 MIN"

[*][1][1] Remote operation ID

- Enter a 3-digit number except a number using 0 or 7.

[*][1][3] Dialing mode

- [1]: "PULSE"
- [2]: "TONE" (default)

[*][1][7] Ringer pattern

- [1]: "A" (default)
- [2]: "B"
- [3]: "C"

[*][2][2] Journal report

- [1]: "ON" (default)
- [2]: "OFF"

[*][2][3] Overseas mode

- [1]: "NEXT FAX"
- [2]: "OFF"
- [3]: "ERROR" (default)

[*][2][5] Delayed transmission

- [1]: "ON"
- [2]: "OFF" (default)
- If you select "ON", then enter the fax number and transmission time using the dial keypad (see feature #25 on page 52 for details).

[*][2][6] Caller ID list

- [1]: "ON"
- [2]: "OFF" (default)

[*][3][1] Distinctive Ring

- [1]: "ON"
- [2]: "OFF" (default)

[*][3][2] Ring pattern for Distinctive Ring

- [1]: "A"
- [2]: "B"
- [3]: "C"
- [4]: "D"
- [5]: "B-D" (default)

[*][3][4] Quick scan

- [1]: "ON"
- [2]: "OFF" (default)

[*][3][6] Receiving reduction

- [1]: "92%" (default)
- [2]: "86%"
- [3]: "72%"
- [4]: "100%"

[*][3][9] Display contrast

- [1]: "NORMAL" (default)
- [2]: "DARKER"

[*][4][1] Fax activation code

- [1]: "ON" (default)
- [2]: "OFF"
- If you select "ON", enter your code from 2 to 4 digits using 0-9, [*] and [#].

[*][4][2] Message alert

- [1]: "ON"
- [2]: "OFF" (default)

[*][4][3] Recording time alert

- [1]: "ON"
- [2]: "OFF" (default)

[*][4][4] Memory reception alert

- [1]: "ON" (default)
- [2]: "OFF"

[*][4][6] Friendly reception

- [1]: "ON" (default)
- [2]: "OFF"

[*][4][7] Fax voice guidance

- [1]: "ON" (default)
- [2]: "OFF"
- [3]: "ERROR"

[*][5][1] Mailbox 1 password

- Enter a 3-digit number except a number using 0 or 7.

[*][5][2] Mailbox 2 password

- Enter a 3-digit number except a number using 0 or 7.

[*][5][4] Greeting time

- [1]: "16s" (default)
- [2]: "60s"

[*][5][5] Greeting message for mailbox 1

- [1]: "CHECK" (default)
- [2]: "RECORD"
- [3]: "ERASE"

[#][5][6] Greeting message for mailbox 2

- **[1]**: "CHECK" (default)
- **[2]**: "RECORD"
- **[3]**: "ERASE"

[#][6][0] Message transfer

- **[1]**: "ON"
- **[2]**: "OFF" (default)
- If you select "ON", enter the transfer telephone number and press **[SET]**, then press **[MENU]** to exit programming.

[#][6][1] Message transfer greeting message

- **[1]**: "CHECK" (default)
- **[2]**: "RECORD"
- **[3]**: "ERASE"

[#][6][7] Incoming message monitor

- **[1]**: "ON" (default)
- **[2]**: "OFF"

[#][7][0] Pager call

- **[1]**: "ON"
- **[2]**: "OFF" (default)
- If you select "ON", enter the pager number using the dial keypad (see page 49 for details).

[#][7][6] Connecting tone

- **[1]**: "ON" (default)
- **[2]**: "OFF"

[#][7][7] AUTO ANSWER

- **[1]**: "FAX ONLY"
- **[2]**: "TAM/FAX" (default)

[#][8][0] Reset advanced features

- **[1]**: "YES"
- **[2]**: "NO" (default)
- If you select "YES", press **[SET]** 2 times, then press **[MENU]** to exit programming.

9.1 Error messages – Reports

If a problem occurs during fax transmission or reception, one of the following communication messages will be printed on the sending and journal reports (page 31).

COMMUNICATION ERROR (Code: 40-42, 46-72, FF)

- A transmission or reception error occurred. Try again or check with the other party.

COMMUNICATION ERROR (Code: 43, 44)

- A line problem occurred. Connect the telephone line cord to a different jack and try again.
- An overseas transmission error occurred. Try using the overseas mode (feature #23, page 52).

DOCUMENT JAMMED

- The document is jammed. Remove the jammed document (page 66).

ERROR-NOT YOUR UNIT (Code: 54, 59, 70)

- A transmission or reception error occurred because of a problem with the other party's fax machine. Check with the other party.

JUNK FAX PROH. REJECT

- The junk fax prohibitor of your fax machine rejected fax reception.

MEMORY FULL

- The memory is full of received documents due to a lack of recording paper or a recording paper jam. Install paper (page 12) or clear the jammed paper (page 63).

NO DOCUMENT

- The document was not fed into the unit properly. Re-insert it and try again.

OTHER FAX NOT RESPONDING

- The other party's fax machine is busy or has run out of recording paper. Try again.
- The document was not fed properly. Re-insert the document and try again.
- The other party's fax machine rings too many times. Send the fax manually (page 30).
- The other party's machine is not a fax machine. Check with the other party.
- The number you dialed is not in service.

PRESSED THE STOP KEY

- **[STOP]** was pressed and fax communication was canceled.

OK

- Fax communication was successful.

9.2 Error messages – Display

If the unit detects a problem, one or more of the following messages will appear on the display.

CALL SERVICE

CALL SERVICE 2

- There is something wrong with the unit. Contact our service personnel.

CHECK DOCUMENT

- The document was not fed into the unit properly. Re-insert the document. If misfeeding occurs frequently, clean the document feeder rollers (page 67) and try again.
- Attempted to transmit a document longer than 600 mm (23⁵/₈"). Press **[STOP]** to remove the document. Divide the document into two or more sheets and try again.

CHECK FILM

- The ink film is empty. Replace the ink film with a new one (page 11).
- The ink film is not installed. Install it (page 10).
- The ink film is slack or creased. Tighten it (see step 5 on page 10).

CHECK MEMORY

- The memory (telephone numbers, parameters, etc.) has been erased. Re-program.

CHECK PAPER

- The recording paper is not installed or the unit has run out of paper. Install paper and press **[START]** to clear the message.

- The recording paper was not fed into the unit properly (page 65). Reinstall paper (page 12) and press **[START]** to clear the message.
- The recording paper has jammed near the recording paper entrance. Clear the jammed paper (page 63) and press **[START]** to clear the message.

CLOSE
TENSION PLATE

- The tension plate is open. Close it (page 12).

COVER OPEN

- The back cover is open. Close it.

DIRECTORY FULL

- There is no space to store new items in navigator directory. Erase unnecessary items (page 25).

FAX IN MEMORY

- The unit has a document in memory. See the other displayed message instructions to print out the document.

FAX MEMORY FULL

- The memory is full of received documents due to a lack of recording paper or a recording paper jam. Install paper (page 12) or clear the jammed paper (page 63).
- When performing memory transmission, the document being stored exceeded the memory capacity of the unit. Transmit the entire document manually.

FILM EMPTY

- The ink film is empty. Replace the ink film with a new one (page 11).
- The ink film is slack. Tighten it (see step 5 on page 10) and install again.
- The fax machine is positioned near appliances such as TVs or speakers which generate an intense magnetic field.

FILM NEAR EMPTY

- The remaining ink film is low. Prepare a new ink film (page 8).

MEMORY FULL

- When making a copy, the document being stored exceeded the memory capacity of the unit. Press **[STOP]** to clear the message. Divide the document into sections.

MESSAGE FULL

- There is no room left in memory to record voice messages. Erase unnecessary messages (page 43, 47).

MODEM ERROR

- There is something wrong with the modem circuit. Contact our service personnel.

NO FAX REPLY

- The other party's fax machine is busy or has run out of recording paper. Try again.

OPEN CABINET
CHECK FILM SLACK



OPEN CABINET
CHECK FILM TYPE

- Please use genuine Panasonic replacement film (page 8).
- The ink film is empty. Replace the ink film with a new one (page 11).
- The ink film is not installed. Install it (page 10).
- The ink film is slack. Tighten it (see step 5 on page 10).
- The fax machine is positioned near appliances such as TVs or speakers which generate an intense magnetic field.

PAPER JAMMED

- A recording paper jam occurred. Clear the jammed paper (page 63).

PLEASE WAIT

9. Help

- The unit is checking that there is no slack or crease on the ink film. Wait for a moment while the check is completed.

REDIAL TIME OUT

- The other party's fax machine is busy or has run out of recording paper. Try again.

REMOVE DOCUMENT

- The document is jammed. Remove the jammed document (page 66).

TRANSMIT ERROR

- A transmission error occurred. Try again.

UNIT OVERHEATED

- The unit is too hot. Stop using the unit for a while and let the unit cool down.

9.3 When a function does not work, check here

9.3.1 Initial settings

I cannot hear a dial tone.

- If you used a splitter to connect the unit, remove the splitter and connect the unit to the wall jack directly. If the unit operates properly, check the splitter.
- Disconnect the unit from the telephone line and connect the line to a known working telephone. If the working telephone operates properly, contact our service personnel to have the unit repaired. If the working telephone does not operate properly, contact your telephone company.
- The power cord or telephone line cord is not connected. Check the connections.
- If you connected the fax machine through a computer modem, connect the fax machine directly to a telephone line jack.

I cannot make calls.

- The dialing mode setting may be wrong. Change the setting (feature #13, page 51).

The unit does not ring.

- The ringer volume is turned OFF. Adjust it (page 20).
- The TAM ring setting of feature #06 is set to "RINGER OFF". Change to another ring setting (page 51).

9.3.2 General

The unit displays "CHECK PAPER" though the paper is inserted.

- The paper is inserted halfway. Insert it correctly (page 12) and press **[START]** to clear the message.

The other party complains they only hear a fax tone and cannot talk.

- FAX ONLY mode is set. Tell the other party the number is only used for faxes.
- Change the receiving mode:
 - TAM/FAX mode (page 35) or TEL mode (page 34)
- If you use a Distinctive Ring service, make sure you have set the same ring pattern assigned by the telephone company (page 38).

The [REDIAL]/[PAUSE] button does not function properly.

- If this button is pressed during dialing, a pause will be inserted. If pressed immediately after a dial tone is obtained, the last number dialed will be redialed.

The receiving mode does not function properly.

- The Distinctive Ring is set (feature #31 on page 38).

During programming, I cannot enter the code or ID number.

- All or part of the numbers are the same as another code or ID. Change the number:
 - remote operation ID: feature #11 on page 51.
 - fax activation code: feature #41 on page 53.
 - password for mailbox 1: feature #51 on page 53.
 - password for mailbox 2: feature #52 on page 54.

The ink film runs out quickly.

- Even if there are only a few sentences, every page that comes out of the machine is considered as a full page.
- Turn off the following features:
 - sending report: feature #04 on page 51.
 - journal report: feature #22 on page 52.
 - Caller ID list: feature #26 on page 52.

The unit beeps.

- Recording paper/ink film has run out. Press **[STOP]** to stop the beeps and install paper/ink film.

Whenever I try to retrieve my voice mail messages, I am interrupted by the fax tone.

- You are probably entering **[*][#][9]**. This is the default setting for the fax activation code. If you use a voice mail service, turn the fax activation feature OFF or reprogram the activation code (feature #41 on page 53).

The speakerphone is not working.

- Use the speakerphone in a quiet room.
- If you have difficulty hearing the other party, adjust the volume.

9.3.3 Fax – sending

I cannot send documents.

- The other party's fax machine is busy or has run out of recording paper. Try again.
- The other party's machine is not a fax machine. Check with the other party.
- The other party's fax machine failed to answer the fax automatically. Send the fax manually (page 30).

I cannot send a fax overseas.

- Use the overseas transmission mode of feature #23 (page 52).
- Add two pauses at the end of the telephone number or dial manually.

The other party complains that letters on their received document are distorted or not clear.

- If your line has special telephone services such as call waiting, the service may have been activated during fax transmission. Connect the unit to a line that does not have these services.
- An extension telephone on the same line is off the hook. Hang up the extension telephone and try again.
- Try copying the document. If the copied image is clear, there may be something wrong with the other party's machine.

The other party complains that smudges or black lines appear on their received document.

- The scanner glass, white plate or rollers are dirty with correction fluid, etc. Clean them (page 67). Please do not insert the document before correction fluid has dried completely.

9.3.4 Fax – receiving

I cannot receive documents.

- When you have a single telephone line and subscribe to a voice mail service, you must also subscribe to a Distinctive Ring service (page 38).
- The ink film is empty. Replace the ink film with a new one (page 11).

I cannot receive documents automatically.

- The receiving mode is set to TEL mode. Change the receiving mode:
 - TAM/FAX mode (page 35) or FAX ONLY mode (page 35).

9. Help

- The time taken to answer the call is too long. Decrease the number of rings in feature #06 (page 51).
- The greeting message is too long. Record a shorter message (page 42).

The display shows “CONNECTING”, but faxes are not received.

- The incoming call is not a fax. Change the receiving mode:
 - TEL mode (page 34) or TAM/FAX mode (page 35).

A blank sheet is ejected.

- If a blank sheet is ejected after the received document is printed out, the size of the document sent by the other party is as large as, or larger than the recording paper, or the receiving reduction rate is not programmed correctly. Program the proper rate in feature #36 (page 52).
- The other party placed the document in their fax machine the wrong way. Check with the other party.

A white line or a smudge appears on your recording paper.

- The scanner glass, white plate or rollers are dirty with correction fluid, etc. Clean them (page 67). Please do not insert the document before correction fluid has dried completely.

The printing quality is poor.

Please do not reuse the ink film!

Please use genuine Panasonic replacement film. Refer to page 8 for further details.

- The thermal head is dirty. Clean it (page 68).
- Some paper has instructions recommending which side to print on. Try turning the paper over.
- You may have used paper with a cotton and/or fiber content that is over 20%, such as letterhead or resume paper. We recommend smooth paper such as “Hammermill Jet Print” for clearer printing.
- If the printing copy is fine when you copy, the other party sent a faint document. Ask them to send a clearer copy of the document.

The other party complains that they cannot send a document.

- The receiving mode is set to TEL mode. Change the receiving mode:
 - TAM/FAX mode (page 35) or FAX ONLY mode (page 35).

- The memory is full of received documents due to a lack of recording paper or a recording paper jam. Install paper (page 12) or clear the jammed paper (page 63).

I cannot select the desired receiving mode.

- If you want to set TAM/FAX or FAX ONLY mode:
 - Set the desired mode using feature #77 (page 54), and press **[AUTO ANSWER]** repeatedly to select the desired mode.
- If you want to set TEL mode, press **[AUTO ANSWER]** repeatedly to select TEL mode.

9.3.5 Copying

The unit will not make a copy.

- The ink film is empty. Replace the ink film with a new one (page 11).
- You cannot make a copy during programming. Make the copy after programming.
- You cannot make a copy during telephone conversation.

A black line, a white line or smudge appears on the copied document.

- The scanner glass, white plate or rollers are dirty with correction fluid, etc. Clean them (page 67). Please do not insert the document before correction fluid has dried completely.

The copied image is distorted.

- The thermal head is dirty. Clean it (page 68).

The printing quality is poor.

Please do not reuse the ink film!

Please use genuine Panasonic replacement film. Refer to page 8 for further details.

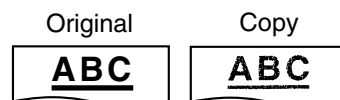

- Some paper has instructions recommending which side to print on. Try turning the paper over.
- You may have used paper with a cotton and/or fiber content that is over 20%, such as letterhead or resume paper. We recommend smooth paper such as “Hammermill Jet Print” for clearer printing.

9.3.6 Answering machine

I cannot retrieve recorded messages from a remote location.

- Press the remote operation ID correctly and firmly (page 44).

Messages in the mailbox do not play back.

- The mailbox password is wrong. Enter the correct password.
 - For mailbox 1 password, see feature #51 (page 53).
 - For mailbox 2 password, see feature #52 (page 54).

The other party complains that they cannot leave a voice message.

- The memory is full. Erase unnecessary messages (page 43, 47).

9.3.7 If a power failure occurs

- The unit will not function.
- The unit is not designed for making emergency telephone calls when the power fails. Alternative arrangements should be made for access to emergency services.
- Fax transmission and reception will be interrupted.
- If delayed transmission (feature #25, page 52) is programmed and the start time is passed during a power failure, transmission will be attempted soon after power is restored.
- If any fax documents are stored in the memory, they will be lost. When power is restored, a power down report will be printed out stating which contents in the memory have been erased.

9.4 Recording paper jams

9.4.1 When the recording paper has jammed in the unit

The display will show the following.

PAPER JAMMED

- 1 Pull the tension plate forward (①) to remove the installed paper (②).
 - Do not remove the jammed paper (③).

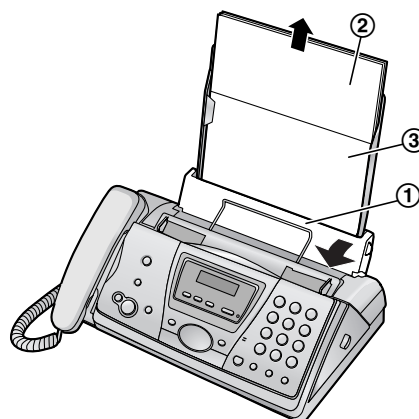

- 2 Remove the paper tray (①).

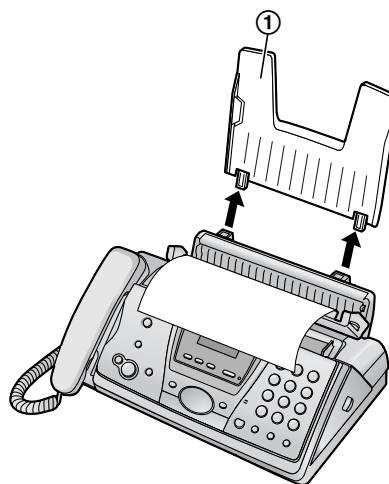

9. Help

- 3 Open the front cover by pulling up the center part.

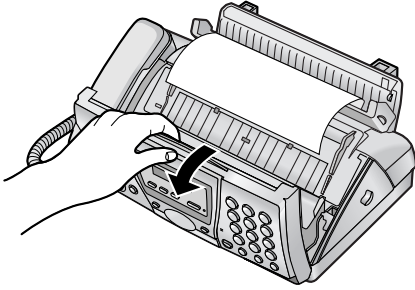

- 4 Release the back cover by pushing the green button (1).

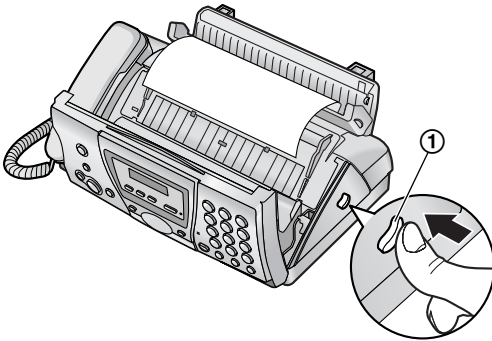

- 5 Open the back cover.

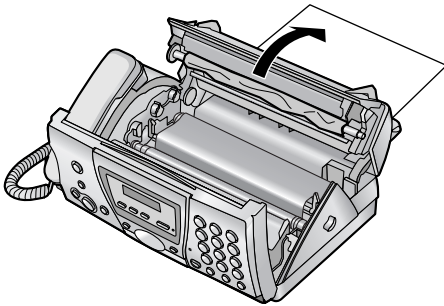

- 6 Remove the jammed recording paper (1).

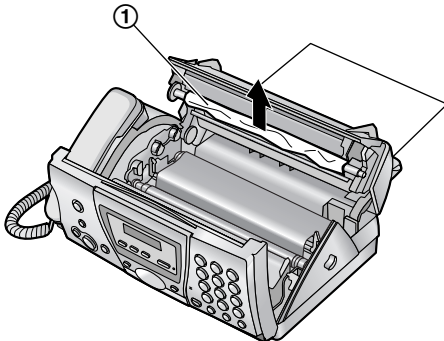

- 7 Turn the blue gear (1) in the direction of the arrow until the ink film is tight (2).

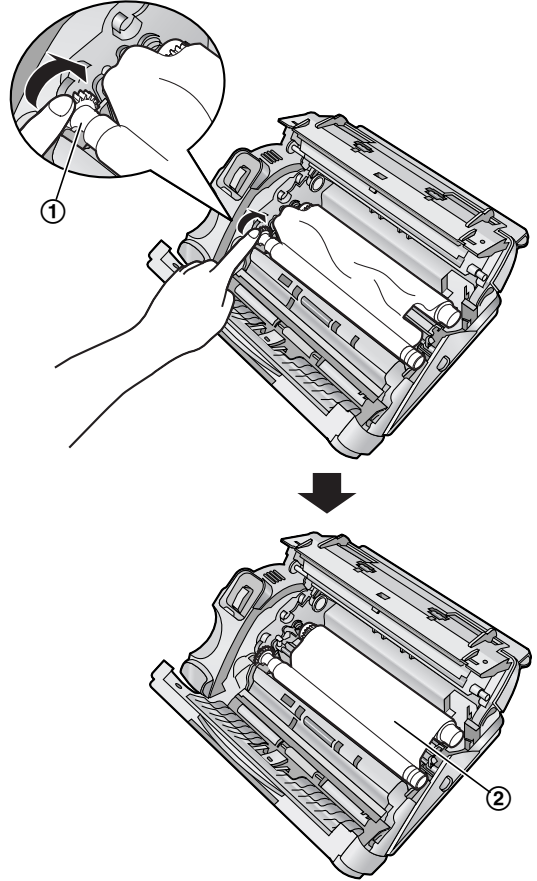

- Make sure that the ink film is wrapped around the blue core (3) at least once.

Correct

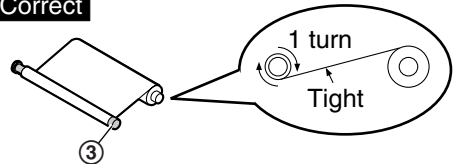

Incorrect

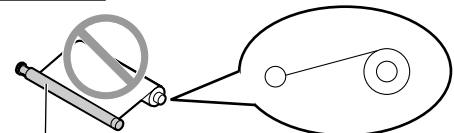

The ink film is not wrapped around the blue core.

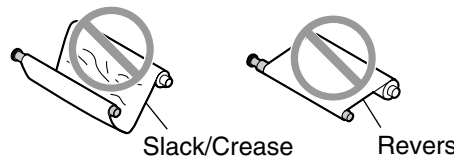

- 8** Close the back cover securely by pushing down on the notched area at both ends (①).

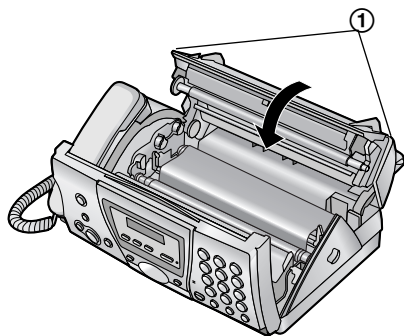

- 9** Close the front cover securely.

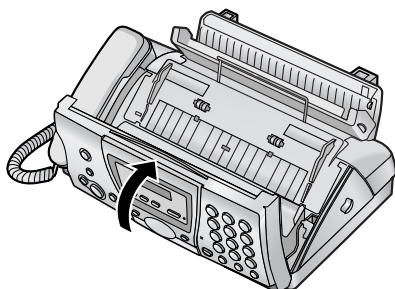

- 10** Install the paper tray (page 12), then insert the recording paper (page 12).

9.4.2 When the recording paper was not fed into the unit properly

The display will show the following.

CHECK PAPER

Remove the recording paper and straighten. Pull the tension plate forward (①) and insert the paper. Push the tension plate back, then press **[START]** to clear the message.

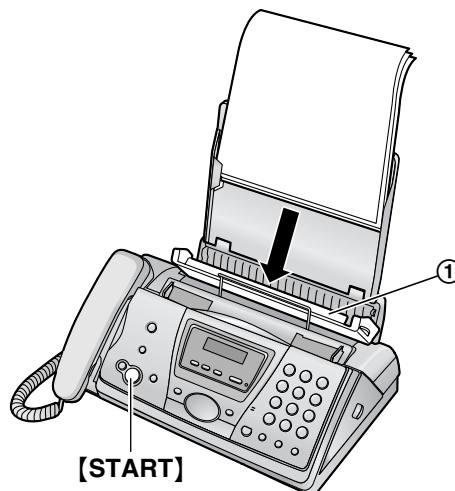

9.5 Document jams – sending

- 1 Open the front cover by pulling up the center part. Remove the jammed document carefully (①).

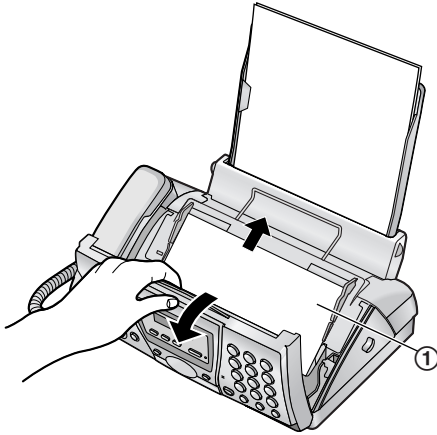

- 2 Close the front cover securely.

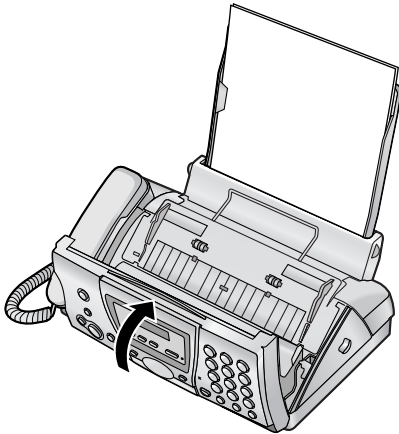

Note:

- Do not pull out the jammed paper forcibly before opening the front cover.



9.6 Recording paper feeder cleaning

Clean the recording paper feeder when:

- The recording paper frequently misfeeds.

Important:

- Remove the recording paper and the paper tray beforehand, or the paper may misfeed or jam.

- 1 Disconnect the power cord and the telephone line cord.
- 2 Open the front cover by pulling up the center part.

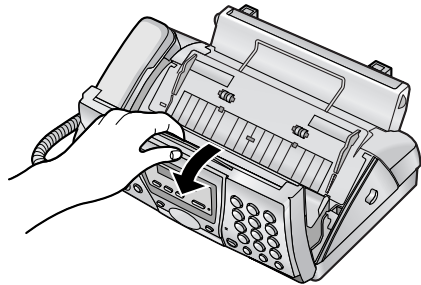

- 3 Release the back cover by pushing the green button (①).

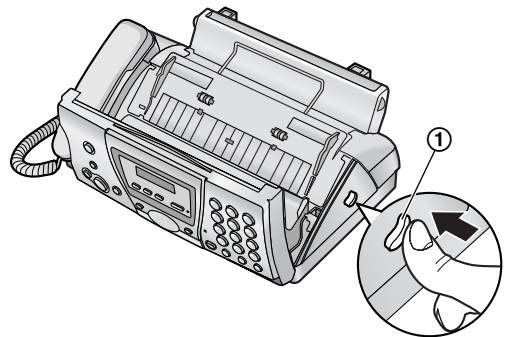

- 4 Open the back cover.

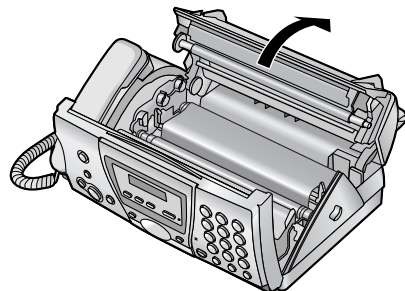

- 5 Open the recording paper feeder cover (①).

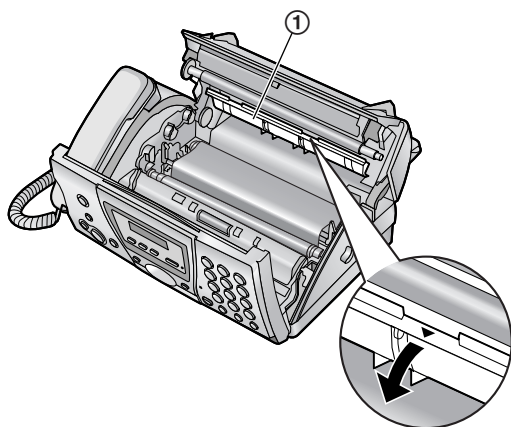

- 6 Clean the recording paper feeder roller (①) with a cloth moistened with isopropyl rubbing alcohol, and let all parts dry thoroughly.

Caution:

- Do not use paper products, such as paper towels or tissues.

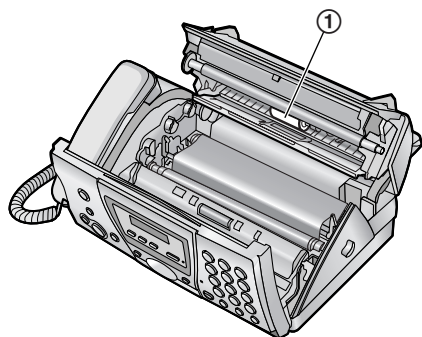

- 7 Close the covers (see steps 8 and 9 on page 65).
- 8 Install the paper tray (page 12), then insert the recording paper (page 12).
- 9 Connect the power cord and the telephone line cord.

9.7 Document feeder/scanner glass cleaning

Clean the document feeder/scanner glass when:

- Documents frequently misfeed.
- Smudges or black/white lines appear on the original document when transmitting or copying.

- 1 Disconnect the power cord and the telephone line cord.
- 2 Open the front cover by pulling up the center part.

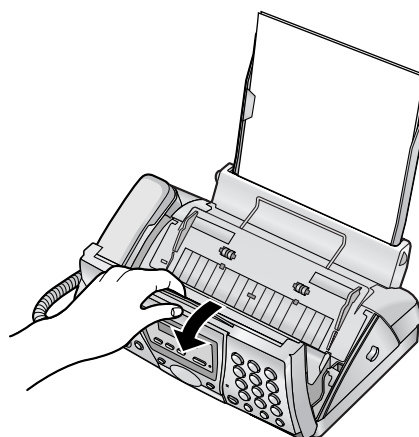

- 3 Clean the document feeder rollers (①) and rubber flap (②) with a cloth moistened with isopropyl rubbing alcohol, and let all parts dry thoroughly. Clean the scanner glass (③) and white plate opposite the scanner glass (④) with a soft, dry cloth.

Caution:

- Do not use paper products, such as paper towels or tissues.

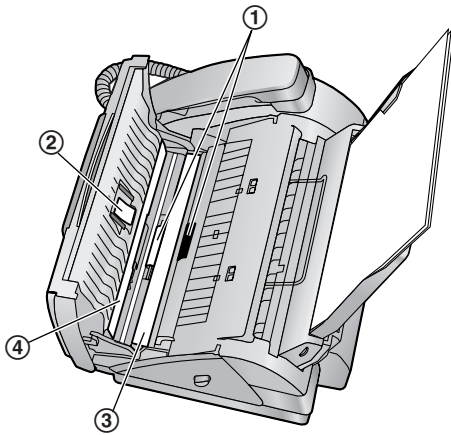

- 4 Close the front cover securely.

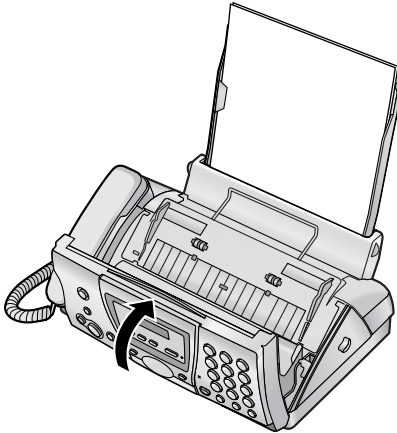

- 5 Connect the power cord and the telephone line cord.

9.8 Thermal head cleaning

If smudges or black/white lines appear on a copied/received document, check whether there is dust on the thermal head. Clean the thermal head to remove the dust.

Important:

- Remove the recording paper and the paper tray beforehand, or the paper may misfeed or jam.

- 1 Disconnect the power cord and the telephone line cord.
- 2 Open the front cover by pulling up the center part.

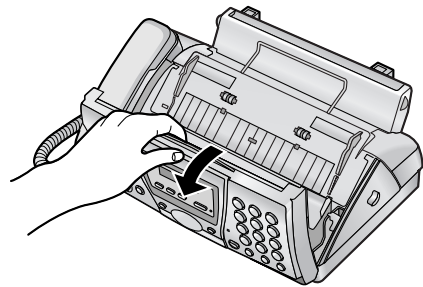

- 3 Release the back cover by pushing the green button (1).

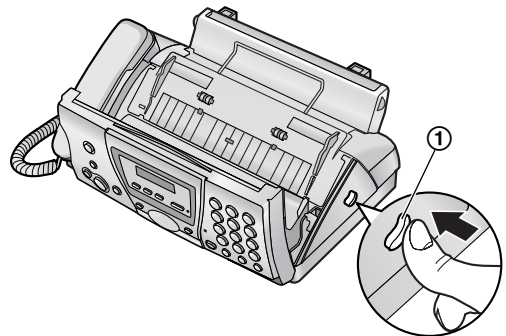

- 4 Open the back cover.

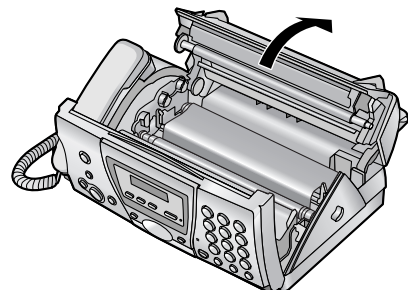

- 5 Remove the ink film (①).

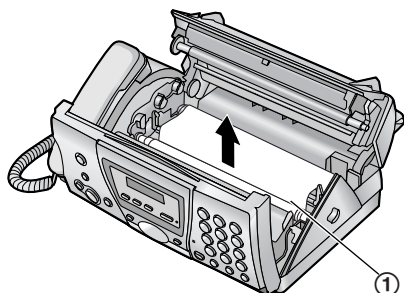

- 6 Clean the thermal head (①) with a cloth moistened with isopropyl rubbing alcohol, and let it dry thoroughly.

Caution:

- To prevent a malfunction due to static electricity, do not use a dry cloth and do not touch the thermal head directly.

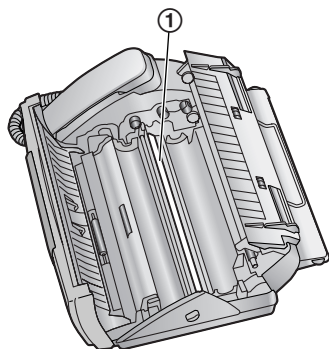

- 7 Reinstall the ink film and close the covers (see steps 4 to 7 on page 10).
- 8 Install the paper tray (page 12), then insert the recording paper (page 12).
- 9 Connect the power cord and the telephone line cord.

10.1 openLCR service for the Caller IQ feature

This unit is compatible with service provided by openLCR.

- If you have any questions regarding the openLCR service, call openLCR's customer service department at 1-866-openLCR (1-866-673-6527).
- NEITHER PANASONIC COMMUNICATIONS CO., LTD. (PCC) NOR MATSUSHITA ELECTRIC CORPORATION OF AMERICA (MECA) IS IN ANY WAY AFFILIATED WITH, OR RESPONSIBLE FOR THE ACTS OR OMISSIONS OF, OPENLCR.COM, INC. (OPENLCR). NEITHER PCC NOR MECA NOR ANY OF THEIR EMPLOYEES OR AFFILIATES OR CUSTOMERS MAKE ANY WARRANTIES OR REPRESENTATIONS, EITHER EXPRESS OR IMPLIED, TO ANY CUSTOMER OR ANY OTHER THIRD PARTY WITH RESPECT TO ANY OF THE SERVICES PROVIDED BY OPENLCR, NOR ASSUME NOR CREATE ANY OTHER OBLIGATION OF ANY KIND ON BEHALF OF OPENLCR.
- If you subscribe to openLCR service, the unit will start the first download of the rate table to your fax machine and the Caller IQ feature will be automatically turned ON. No special dialing or button pressing is necessary to place a long distance call with the Caller IQ feature.

If you do not wish to use the Caller IQ feature, you can turn it OFF temporarily.

Note:

- Before subscribing to openLCR service, you cannot change the following settings.

10.2 To turn the Caller IQ ON / OFF

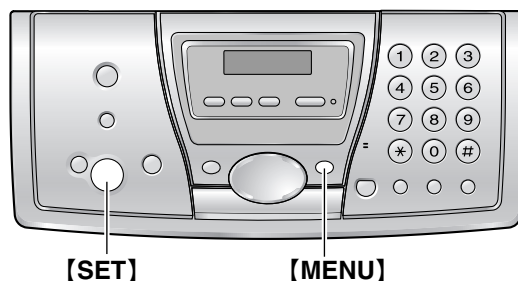

- 1 Press **[MENU]** repeatedly to display the following.

```
CALLER IQ  
PRESS NAVI. [◀ ▶]
```

- 2 Press **[0]**.

- 3 **To turn ON:**
Press **[1]**.
To turn OFF:
Press **[3]**.

- 4 Press **[SET]**.

- During a long distance call with Caller IQ feature, the display shows the following.

Example:

```
00'17 [CIQ]
```

10.3 Updating the rate table (downloading the rate table)

If you register through the openLCR web site or move to another area, you have to download the rate table manually.

- Keep the front cover page open for button locations.

- 1 Press **[MENU]** repeatedly to display the following.

```
CALLER IQ  
PRESS NAVI. [◀ ▶]
```

- 2 Press **[#]**.

- 3 Press **[SET]**.

- 4 Follow the voice prompt to start downloading.

During download

- The display will show the following.

DOWNLOADING

- While downloading, you cannot do other operations such as making/answering calls or sending/receiving documents.
- Depending on where you live, the call for downloading may be a long distance call and will take about 1-2 minutes. You will be charged for the cost of the call.
- When the download is completed, the display will show "DOWNLOAD OK!"
- If "DOWNLOAD ERROR. TRY AGAIN." is displayed, the unit was unable to download from openLCR. Try downloading manually again.

Automatic download

The fax machine will automatically download the latest rate table when:

- the rate table in the fax machine reaches the expiry date; usually between 60-90 days after last update,
- the fax machine is being polled by openLCR service center.

To stop downloading

1. Press **[STOP]**.
2. Press **[SET]**.

10.4 Downloading information

This enables you to view information such as weather, lottery results and stock quotes on the LCD display. Each time you download the data from openLCR, the information will be updated. To view up-to-date information, you will need to download the information to your unit.

If you access the openLCR web site at **www.openLCR.com** and program the system setup and phone book, you will need to download this data to the fax machine.

- Keep the front cover page open for button locations.

- 1 Press **[MENU]** repeatedly to display the following.

CALLER IQ
PRESS NAVI. [◀ ▶]

- 2 Press **[#]**.

- 3 Press **[SET]**.

- 4 Follow the voice prompt to start downloading.

10.5 Viewing information

- Keep the front cover page open for button locations.

- 1 Press **[MENU]** repeatedly to display the following.

CALLER IQ
PRESS NAVI. [◀ ▶]

- 2 Press **[2]**.

- 3 Press **[SET]**.

- The items of information which you selected on the web are displayed.

Example:

openLCR.com
1: Weather



2: Stock

- 4 Select the desired information by pressing the desired information number, using the dial keypad.

- 5 Press **[+]** or **[-]** repeatedly to find more information.

- 6 Press **[MENU]** to stop viewing.

10.6 Printing information

- Keep the front cover page open for button locations.

- 1 Press **[MENU]** repeatedly to display the following.

CALLER IQ
PRESS NAVI. [◀ ▶]

- 2 Press **[1]**.

- 3 Press **[SET]** to start printing.

11.1 Reference lists and reports

You can print out the following lists and reports for your reference.

Setup list:

provides you with the current settings of the basic and advanced programming features (page 51 to page 55).

Telephone number list:

provides you with names and numbers which are stored in the navigator directory.

Journal report:

keeps records of fax transmission and reception. This report will be printed automatically after every 30 fax communications (feature #22, page 52).

Printer test:

allows you to check the print quality of your unit. If the test print has a smudge, or blurred points or lines, clean the thermal head (page 68).

Broadcast programming list:

provides you with names and numbers which are stored in the broadcast memory (page 32).

Caller ID list:

keeps records of the last 30 callers after subscribing to a Caller ID service. To print automatically after every 30 callers, activate feature #26 (page 52).

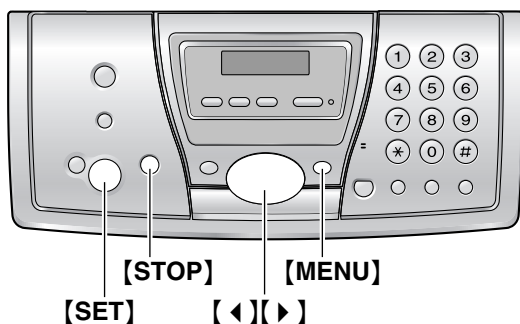

- 1 Press **[MENU]** repeatedly to display "PRINT REPORT".
- 2 Press **[<]** or **[>]** repeatedly to display the desired item.
- 3 Press **[SET]** to start printing.
 - To stop printing, press **[STOP]** 2 times.
- 4 Press **[MENU]**.

11.2 Technical data about this product

Applicable lines:	Public Switched Telephone Network
Document size:	Max. 216 mm (8 ¹ / ₂ ") in width, Max. 600 mm (23 ⁵ / ₈ ") in length
Effective scanning width:	208 mm (8 ³ / ₁₆ ")
Effective printing width:	Letter: 208 mm (8 ³ / ₁₆ ")
Transmission time^{*1}:	Approx. 9 s/page (Original mode) ^{*2}
Scanning density:	Horizontal: 8 pels/mm (203 pels/inch) Vertical: 3.85 lines/mm (98 lines/inch) - in standard resolution, 7.7 lines/mm (196 lines/inch) - in fine/photo resolution, 15.4 lines/mm (392 lines/inch) - in super fine resolution
Photo resolution:	64 levels
Scanner type:	Contact Image Sensor
Printer type:	Thermal Transfer on plain paper
Data compression system:	Modified Huffman (MH), Modified READ (MR)
Modem speed:	14,400 / 12,000 / 9,600 / 7,200 / 4,800 / 2,400 bps; Automatic Fallback
Operating environment:	5°C – 35°C (41°F – 95°F), 20% – 80% RH (Relative Humidity)
Dimensions:	Approx. height 139 mm × width 331 mm × depth 238 mm (5 ¹⁵ / ₃₂ " × 13 ¹ / ₃₂ " × 9 ³ / ₈ ")
Mass (Weight):	Approx. 3.0 kg (6.6 lb.)
Power consumption:	Standby: Approx. 3.2 W Transmission: Approx. 15 W Reception: Approx. 35 W (When receiving a 20% black document) Copy: Approx. 40 W (When copying a 20% black document) Maximum: Approx. 130 W (When copying a 100% black document)
Power supply:	120 V AC, 60 Hz
Fax memory capacity:	Approx. 25 pages of memory transmission Approx. 28 pages of memory reception (Based on the ITU-T No. 1 Test Chart in standard resolution.)
Voice memory capacity^{*3}:	Approx. 18 minutes of recording time including greeting messages

*1 Transmission speed depends upon the contents of the pages, resolution, telephone line conditions and capability of the other party's machine.

*2 Transmission speed is based upon the ITU-T No. 1 Test Chart and original mode. If the capability of the other party's machine is inferior to your unit, the transmission time may be longer.

*3 Recording time may be reduced by the calling party's background noise.

ITU-T No. 1 Test Chart

①

THE SLEREXE COMPANY LIMITED
SAPORI LAURE - BOLOGNA - CORSEY - SUD 4 1/2 E
SAPORI LAURE - BOLOGNA - CORSEY - SUD 4 1/2 E

Our Ref. 350/PK/EGC 18th January, 1972.

Dr. P.H. Omdall,
Mining Survey Ltd.,
Midford Road,
Berkeley.

Dear Peter,

Permit me to introduce you to the facility of facsimile transmission.

In facsimile a photocell is caused to perform a raster scan over the subject copy. The variations of print density on the document cause the photocell to generate an analogous electrical video signal. This signal is then to modulate a carrier, which is transmitted to a remote destination over a radio or cable communications link.

At the remote terminal, demodulation reconstructs the video signal, which is used to modulate the intensity of print produced by a printing device. This device is arranged to a raster with synchronised scan lines at the transmitting terminal. As a result, a facsimile copy of the subject document is produced.

Probably you have seen this facility in your organisation.

Yours sincerely,

P.H.
P.J. CROSS
Group Leader - Facsimile Research

11. General Information

Paper specifications

Recording paper size: Letter: 216 mm × 279 mm (8¹/₂" × 11")
Recording paper weight: 60 g/m² to 90 g/m² (16 lb. to 24 lb.)

Note for recording paper:

- Do not use the following types of paper:
 - Paper with a cotton and/or fiber content that is over 20%, such as letterhead paper or paper used for resumes
 - Extremely smooth or shiny paper, or paper that is highly textured
 - Coated, damaged or wrinkled paper
 - Paper with foreign objects attached, such as tabs or staples
 - Paper which has dust, lint or oil stains
 - Paper that will melt, vaporize, discolor, scorch or emit dangerous fumes near 200 °C (392°F), such as vellum paper. These materials may transfer onto the fusing roller and cause damage.
 - Moist paper
- Some paper only accepts print on one side. Try using the other side of the paper if you are not happy with the print quality or if misfeeding occurs.
- For proper paper feeding and best print quality, we recommend using long-grained paper.
- Do not use paper of different types or thickness at the same time. This may cause a paper jam.
- Avoid double-sided printing.
- Do not use paper printed from this unit for double-sided printing with other copiers or printers. This may cause a paper jam.
- To avoid curling, do not open paper packs until you are ready to use the paper. Store unused paper in the original packaging, in a cool and dry location.
- This unit is designed for using "Letter" size paper. Please do not use "A4" size paper for this unit.

Note:

- Any details given in these instructions are subject to change without notice.
- The pictures and illustrations in these instructions may vary slightly from the actual product.

11.3 FCC and Other Information

This equipment complies with Part 68 of the FCC rules and the requirements adopted by the ACTA. On the rear of this equipment is a label that contains, among other information, a product identifier in the format US:ACJ-----.

If requested, this number must be provided to the telephone company.

- Registration No(found on the rear of the unit)
- Ringer Equivalence No. (REN)
.....(found on the rear of the unit)

A plug and jack used to connect this equipment to the premises wiring and telephone network must comply with the applicable FCC Part 68 rules and requirements adopted by the ACTA. A compliant telephone cord and modular plug is provided with this product. It is designed to be connected to a compatible modular jack that is also compliant.

The REN is used to determine the number of devices that may be connected to a telephone line. Excessive RENs on a telephone line may result in the devices not ringing in response to an incoming call. In most but not all areas, the sum of RENs should not exceed five (5.0). To be certain of the number of devices that may be connected to a line, as determined by the total RENs, contact the local telephone company. For products approved after July 23, 2001, the REN for this product is part of the product identifier that has the format US:AAAEQ##TXXXX. The digits represented by ## are the REN without a decimal point (e.g., 03 is a REN of 0.3).

If this equipment causes harm to the telephone network, the telephone company will notify you in advance that temporary discontinuance of service may be required. But if advance notice isn't practical, the telephone company will notify the customer as soon as possible. Also, you will be advised of your right to file a complaint with the FCC if you believe it is necessary.

The telephone company may make changes in its facilities, equipment, operations or procedures that could affect the operation of the equipment. If this happens the telephone company will provide advance notice in order for you to make necessary modifications to maintain uninterrupted service.

If trouble is experienced with this equipment, for repair or warranty information, please contact a Factory Servicenter or other Authorized Servicer. If the equipment is causing harm to the telephone network, the telephone company may request that you disconnect the equipment until the problem is resolved.

Connection to party line service is subject to state tariffs. Contact the state public utility commission, public service commission or corporation commission for information.

This equipment is hearing aid compatible as defined by the FCC in 47 CFR Section 68.316.

If your home has specially wired alarm equipment connected to the telephone line, ensure the installation of this equipment does not disable your alarm equipment. If you have questions about what will disable alarm equipment, consult your telephone company or a qualified installer.

WHEN PROGRAMMING EMERGENCY NUMBERS AND(OR) MAKING TEST CALLS TO EMERGENCY NUMBERS:

- 1) Remain on the line and briefly explain to the dispatcher the reason for the call.
- 2) Perform such activities in the off-peak hours, such as early morning or late evenings.

The software contained in this equipment to allow user access to the network must be upgraded to recognize newly established network area codes and exchange codes as they are placed into service. Failure to upgrade the premises systems or peripheral equipment to recognize the new codes as they are established will restrict the customer and the customer's employees from gaining access to the network and to these codes.

NOTE:

Many states have imposed regulations on the manner in which 2-way telephone conversations may be recorded, so you should inform the other party that the conversation is being recorded. Consult your local telephone company for further information.

CAUTION:

Any changes or modifications not expressly approved by the party responsible for compliance could void the user's authority to operate this device.

11. General Information

NOTE:

This equipment has been tested and found to comply with the limits for a Class B digital device, pursuant to Part 15 of the FCC Rules. These limits are designed to provide reasonable protection against harmful interference in a residential installation. This equipment generates, uses, and can radiate radio frequency energy and, if not installed and used in accordance with the instructions, may cause harmful interference to radio communications. However, there is no guarantee that interference will not occur in a particular installation. If this equipment does cause harmful interference to radio or television reception, which can be determined by turning the equipment off and on, the user is encouraged to try to correct the interference by one or more of the following measures:

- Reorient or relocate the receiving antenna.
- Increase the separation between the equipment and receiver.
- Connect the equipment into an outlet on a circuit different from that to which the receiver is connected.
- Consult the dealer or an experienced radio/TV technician for help.

11.4 Limited Warranty

PANASONIC CONSUMER ELECTRONICS COMPANY,
DIVISION OF MATSUSHITA ELECTRIC
CORPORATION OF AMERICA
One Panasonic Way,
Secaucus, New Jersey 07094

PANASONIC SALES COMPANY,
DIVISION OF MATSUSHITA
ELECTRIC OF PUERTO RICO, INC.,
Ave. 65 de Infantería, Km. 9.5
San Gabriel Industrial Park,
Carolina, Puerto Rico 00985

Panasonic Facsimile Product Limited Warranty

Limited Warranty Coverage

If your product does not work properly because of a defect in materials or workmanship, Panasonic Consumer Electronics Company or Panasonic Sales Company (collectively referred to as “the warrantor”) will, for the length of the period indicated on the chart below, which starts with the date of original purchase (“Limited Warranty period”), at its option either (a) repair your product with new or refurbished parts, or (b) replace it with a new or a refurbished product. The decision to repair or replace will be made by the warrantor.

FAX categories	Parts	Labor
Thermal Transfer Facsimile	6 Months	6 Months
Laser Facsimile	1 (one) Year	1 (one) Year

Batteries, antennas, optional accessories (such as additional handsets), ink film, toner cartridge, drum unit, and ink cartridge (as may be applicable), and cosmetic parts (cabinet) are not warranted under this Limited Warranty.

During the “Labor” Limited Warranty period there will be no charge for labor. During the “Parts” Limited Warranty period, there will be no charge for parts. You must carry-in or mail-in your product during the Limited Warranty period. This Limited Warranty only applies to products purchased and serviced in the United States or Puerto Rico. This Limited Warranty is extended only to the original purchaser and only covers products purchased as new. A purchase receipt or other proof of the original purchase date is required for Limited Warranty service.

Carry-In or Mail-In Service

For Carry-In or Mail-In Service in the United States call 1-800-HELP-FAX (1-800-435-7329)
For assistance in Puerto Rico call Panasonic Sales Company (787)-750-4300 or fax (787)-768-2910.

Limited Warranty Limits And Exclusions

This Limited Warranty ONLY COVERS failures due to defects in materials or workmanship, and DOES NOT COVER normal wear and tear or cosmetic damage. The Limited Warranty ALSO DOES NOT COVER damages which occurred in shipment, or failures which are caused by products not supplied by the warrantor such as non Panasonic ink film, toner cartridge or drum unit, or failures which result from accidents, misuse, abuse, neglect, mishandling, misapplication, alteration, faulty installation, set-up adjustments, signal reception problems, misadjustment of consumer controls, improper maintenance, power line surge, improper voltage supply, lightning damage, modification, or commercial use (such as in a hotel, office, restaurant, or other business), rental use of the product, service by anyone other than a Factory Servicenter or other Authorized Servicer, or damage that is attributable to acts of God.

THERE ARE NO EXPRESS WARRANTIES EXCEPT AS LISTED UNDER “LIMITED WARRANTY COVERAGE”. THE WARRANTOR IS NOT LIABLE FOR INCIDENTAL OR CONSEQUENTIAL DAMAGES RESULTING FROM THE USE OF THIS PRODUCT, OR ARISING OUT OF ANY BREACH OF THIS LIMITED WARRANTY. (As examples, this excludes damages for lost time, cost of having someone remove or re-install an installed unit if applicable, or travel to and from the servicer. The items listed are not exclusive, but are for illustration only.) **ALL EXPRESS AND IMPLIED WARRANTIES, INCLUDING THE WARRANTY OF MERCHANTABILITY, ARE LIMITED TO THE PERIOD OF THE LIMITED WARRANTY.**

11. General Information

Some states do not allow the exclusion or limitation of incidental or consequential damages, or limitations on how long an implied Limited Warranty lasts, so the exclusions may not apply to you.

This Limited Warranty gives you specific legal rights and you may also have other rights which vary from state to state. If a problem with this product develops during or after the Limited Warranty period, you may contact your dealer or Servicenter. If the problem is not handled to your satisfaction, then write to the warrantor's Consumer Affairs Department at the addresses listed for the warrantor.

PARTS AND SERVICE WHICH ARE NOT COVERED BY THIS LIMITED WARRANTY ARE YOUR RESPONSIBILITY.

For In Limited Warranty product service

- Call toll-free 1-800-HELP-FAX (1-800-435-7329) for the location of an authorized servicenter.

For out of Limited Warranty technical and troubleshooting support: Panasonic offers two value based, cost effective, solutions:

1. Panasonic Continued Services 900 fee based support: 1-900-555-7262

This exceptional service is charged directly to your telephone bill at only \$1.99 per minute.

2. Panasonic Premier Service Club (PPSC): 1-800-435-7329

PPSC provides toll free troubleshooting support at only \$7.99 for a one time sampler or \$23.95 for a one year or 5 call membership. These services are billed directly to your major credit card.

When you ship the product

- Carefully pack your unit, preferably in the original carton.
- Attach a letter, detailing the symptom or problem, to the outside of the carton.
- Send the unit to an authorized servicenter, prepaid and adequately insured.
- Do not send your unit to the Panasonic Consumer Electronics Company or to any executive or regional sales office. These locations do not repair consumer products.

Both of these comprehensive programs provide real time, live agent support for customers who are not eligible for coverage under the limited warranty.

Terms and prices are subject to change without notice.

11.5 Customer Services directory

Customer Services Directory

Obtain Product Information and Operating Assistance; locate your nearest Dealer or Servicenter; purchase Parts and Accessories; or make Customer Service and Literature requests by visiting our Web Site at:

<http://www.panasonic.com/support>

or E-mail us via:

consumer_fax@panasonic.com

Contact:

For in Limited Warranty programming and Troubleshooting Support:

Fax Advantage assistance and Service Location finder: 800-HELP-FAX (435-7329)

For out of Limited Warranty technical and troubleshooting support:

Panasonic offers two value based, cost effective, solutions:

1. Panasonic Continued Services 900 fee based support: 1 900 555 7262

This exceptional service is charged directly to your telephone bill at only \$1.99 per minute.

2. Panasonic Premier Service Club (PPSC): 1 800 435 7329

PPSC provides toll free troubleshooting support at only \$7.99 for a one time sampler or \$23.95 for a one year or 5 call membership. These services are billed directly to your major credit card.

Both of these comprehensive programs provide real time, live agent support for customers who are not eligible for coverage under the limited warranty. Terms and prices are subject to change without notice.

For hearing or speech impaired TTY users, TTY: 1-866-741-6422

Accessory Purchases

Purchase Parts, Accessories and Instruction Books online for all Panasonic Products by visiting our Web Site at:

<http://www.pasc.panasonic.com>

or, send your request by E-mail to:

npcparts@panasonic.com

You may also contact us directly at:

1-800-332-5368 (Phone) 1-800-237-9080 (Fax Only) (Monday - Friday 9 am to 8 pm, EST.)

Panasonic Services Company

20421 84th Avenue South, Kent, WA 98032

(We Accept Visa, MasterCard, Discover Card, American Express, and Personal Checks)

For hearing or speech impaired TTY users, TTY: 1-866-605-1277

Service in Puerto Rico

Matsushita Electric of Puerto Rico, Inc. Panasonic Sales Company

Factory Servicenter:

Ave. 65 de Infantería, Km. 9.5, San Gabriel Industrial Park, Carolina, Puerto Rico 00985

Phone (787) 750-4300 Fax (787) 768-2910

12.1 Index

- # #00 Quick Setup: 15
- # #01 Date and time: 21
- # #02 Your logo: 22
- # #03 Your fax number: 23
- # #04 Sending report: 31, 51
- # #06 FAX ring setting: 51
- # #06 TAM ring setting: 35, 51
- # #10 Recording time for an incoming message: 51
- # #11 Remote operation ID: 31
- # #13 Dialing mode: 51
- # #17 Ringer pattern: 51
- # #22 Journal report: 31, 52
- # #23 Overseas mode: 52
- # #25 Delayed transmission: 52
- # #26 Caller ID list: 52
- # #31 Distinctive Ring: 38
- # #32 Ring pattern: 39
- # #34 Quick scan: 30, 40, 52
- # #36 Receiving reduction: 52
- # #39 Display contrast: 53
- # #41 Fax activation code: 53
- # #42 Message alert: 53
- # #43 Recording time alert: 53
- # #44 Memory reception alert: 53
- # #46 Friendly reception: 53
- # #47 Fax voice guidance: 53
- # #51 Mailbox 1 password: 53
- # #52 Mailbox 2 password: 54
- # #54 Greeting time: 54
- # #55 Mailbox 1 greeting: 46
- # #56 Mailbox 2 greeting: 46
- # #60 Message transfer: 48, 54
- # #61 Message transfer greeting message: 48
- # #67 Incoming message monitor: 54
- # #70 Pager call: 49
- # #76 Connecting tone: 54
- # #77 AUTO ANSWER: 54
- # #80 Reset advanced features: 55
- A** Accessories: 7
 - Paper tray: 12
 - Advanced features: 52
 - AUTO ANSWER setting (Feature #77): 54
- B** Basic features: 51
 - Broadcast transmission: 32
 - Button description: 9
- C** Caller ID: 27
 - Calling back: 27
 - Storing: 29
- Caller ID list (Feature #26): 27, 52
- Caller's recording time (Feature #10): 51
- Character table: 22
- Cleaning: 66, 67, 68
- Communication messages: 58
- Connecting tone (Feature #76): 54
- Connections: 14
- Copy: 40
 - Collation: 41
 - Enlarge: 40
 - Reduce: 40
- D** Date and time (Feature #01): 21
 - Delayed transmission (Feature #25): 52
 - Dialing mode (Feature #13): 51
 - Directory (Navigator): 23, 25, 26, 32
 - Display
 - Contrast (Feature #39): 53
 - Error messages: 58
 - Distinctive Ring service (Feature #31): 38
 - Document size: 31
- E** Error messages: 58
 - Extension telephone: 34
- F** Fax activation code (Feature #41): 53
 - Fax number (Feature #03): 23
 - Fax voice guidance (Feature #47): 53
 - Friendly reception (Feature #46): 53
- G** Greeting message
 - Message transfer (Feature #61): 48
 - TAM/FAX: 42
 - Voice mailbox (Feature #55, #56): 46
- H** Help: 20
- I** Incoming message monitor (Feature #67): 54
 - Ink film
 - Installing: 10
 - Replacing: 11
- J** Jams
 - Document: 66
 - Recording paper: 63
 - Journal report (Feature #22): 31, 52
 - Junk fax prohibitor: 36
- L** Listening to recorded messages: 43
 - From a remote location: 44
 - Voice mailbox: 47, 48
 - Logo (Feature #02): 22
- M** Message alert (Feature #42): 53
 - Message transfer (Feature #60): 48, 54

-
- N** Navigator directory
 - Making a phone call: 26
 - Selecting characters: 23
 - Sending faxes: 32
 - Storing: 25
 - O** Overseas mode (Feature #23): 52
 - P** Pager call (Feature #70): 49
 - Power failure: 63
 - Programming: 50
 - Q** Quick scan (Feature #34): 30, 40, 52
 - Quick Setup (Feature #00): 15
 - R** Receiving alert (Feature #44): 53
 - Receiving faxes
 - Automatically: 35
 - Manually: 34
 - Receiving reduction (Feature #36): 52
 - Recording
 - Greeting message: 42, 46, 48
 - Memo message: 42, 47
 - Telephone conversation: 26
 - Recording paper: 12
 - Recording paper size: 74
 - Recording time alert (Feature #43): 53
 - Recording time for TAM/FAX greeting message (Feature #54): 54
 - Redialing: 30, 32
 - Remote operation: 44
 - Remote operation ID (Feature #11): 51
 - Reports
 - Broadcast programming: 72
 - Broadcast sending: 33
 - Caller ID list: 52, 72
 - Journal: 31, 52, 72
 - Power down: 63
 - Printer test: 72
 - Sending: 31, 51
 - Setup: 72
 - Telephone number: 72
 - Reset (Feature #80): 55
 - Resolution: 30, 40
 - Ringer pattern (Feature #17): 51
 - Ring pattern for Distinctive Ring (Feature #32): 39
 - Ring setting
 - FAX ONLY (Feature #06): 51
 - TAM/FAX (Feature #06): 51
 - S** Sending faxes
 - Broadcast: 33
 - From memory: 30
 - Manually: 30
 - Navigator directory: 32
 - Sending report (Feature #04): 31, 51
 - Storing
 - Broadcast: 32
 - Navigator directory: 25
 - T** Toll saver: 35
 - V** Voice mailbox: 46
 - Voice mailbox password (Feature #51, #52): 46, 53, 54
 - Voice time/day stamp: 43
 - Volume: 20
-

Panasonic
KX-FP145
Proof of Purchase

Panasonic FAX ADVANTAGE PROGRAM

*Free peace of mind,
direct from Panasonic*

NO EXTRA COST



- **6-month limited warranty¹: parts, labor, and toll-free help line²**
- **Free replacement³ and repair program**

The Panasonic Fax Advantage Consumer Service Program.

Panasonic knows that if your fax machine is not up and running, neither is your business. That's why we created the Panasonic Fax Advantage Program. Included at no extra cost with the purchase of a new and unused Panasonic Fax Machine (along with included handset), the Fax Advantage Program can provide a free replacement unit³ if your original unit is in need of repair. **Here's how it works:**

1. If you have a problem with your fax that you purchased new and unused while it is covered by the period of limited warranty¹, call our toll-free help-line at 1-800-HELP-FAX².
2. Talk to one of our technical experts to diagnose your problem over the phone.
3. If repairs are necessary and you are entitled to service under the terms and conditions of the limited warranty⁴, we will send a refurbished replacement unit to you by UPS Ground service delivery. The shipping method is upgradable for an extra charge.

A second option available under our limited warranty is to mail-in or carry-in your fax to one of our Regional Service centers, where the unit will be repaired and returned to you.

Instructions:

If you choose to receive a replacement unit under the Fax Advantage Program, Panasonic will provide a replacement unit which will be completely refurbished, quality-tested by Panasonic technicians and individually hand-inspected before it is shipped to you. You will keep the replacement unit and send the original unit to us in the replacement unit's box. UPS will pick up the unit at no charge to you, should it be determined that you are entitled to warranty service. A proof-of-purchase must be included with the returned product. Any unit that is replaced by Panasonic and not shipped with proper proof-of-purchase by you will be subject to a minimum \$100.00 charge. The original unit must be properly packaged in the same manner as the replacement unit, utilizing the packing materials provided. Damage due to improper or inadequate packing will be charged to you as an out-of-warranty cost.

If our 1-800-HELP-FAX technicians determine that your unit may be an "out-of-box failure"⁵, we will attempt to provide you with a factory-new replacement unit⁶. You must ship a copy of your receipt with your original unit to verify that you purchased the unit within 10 days prior to your 1-800-HELP-FAX call.

Requirements:

You must give our technicians a valid credit card number (Discover, VISA, Master Card, or American Express/Optima). Product that is not returned to Panasonic by 10 business days after shipment of the replacement product will be charged to your credit card account at Panasonic's Suggested Retail Price (see dealer for details). If your original unit is not eligible for warranty service, your card will be charged for the non-warranty repair of the unit at Panasonic's current rate for parts and labor and for any shipping charges associated with this program. If you do not wish to pay out-of-warranty repair costs, you will be responsible for returning the replacement unit to Panasonic and for paying all shipping charges associated with this program including the UPS delivery of the replacement product to you, shipment of the problem unit to Panasonic, shipment of the replacement unit back to Panasonic and the return of your original unit back to you. Credit status will be verified prior to sending the replacement product.

1. See dealer for limited warranty details.
2. After the fax advantage program, contact our Continued Services Technical Support Line at 1-900-555-PANA (1-900-555-7262), for fee based technical support.
3. Replacement unit is refurbished.
4. Replacement program is only available in the 50 United States, is subject to termination at any time without advance notice, and does not cover optional accessories.
5. "Out-of-box failure" is an inoperable unit that was purchased no more than 10 days prior to your 1-800-HELP-FAX call, and would otherwise qualify for warranty service under the terms and conditions of the limited warranty.
6. Panasonic reserves the right to send a refurbished unit.

**Panasonic Consumer Electronics
Company, Division of Matsushita
Electric Corporation of America**

One Panasonic Way,
Secaucus, New Jersey 07094

**Panasonic Sales Company,
Division of Matsushita Electric of
Puerto Rico, Inc.**

Ave. 65 de Infantería, Km. 9.5
San Gabriel Industrial Park, Carolina,
Puerto Rico 00985

PFQX2006ZA CM0204DT0